

Ashland City, Tennessee
American with Disabilities Act
Facilities Inventory Self-Evaluation and Transition Plan

Prepared for:



101 Court Street
Ashland City, TN 37015

Prepared by:



1116 MAIN STREET
PLEASANT VIEW, TN 37146

November 30, 2019

Table of Contents

1.0	INTRODUCTION/PURPOSE	1
2.0	PEDESTRIAN FACILITY INVENTORY	2
3.0	INVENTORY FINDINGS	2
3.1	Public Buildings	3
3.1.1	Public Buildings-Interior	3
3.1.2	Public Buildings-Parking Lots	5
3.1.3	Public Buildings-Sidewalks, Curb Ramps	5
3.2	Parks and Trailheads	6
3.2.1	Parks and Trailheads	6
3.2.2	Parks and Trailheads-Parking Lots	9
3.2.3	Parks and Trailheads-Sidewalks, Curb Ramps	10
3.3	Signalized Intersections	11
3.4	Pedestrian Facilities within the Public Right-Of-Way	16
3.4.1	Pedestrian Pathways Summary of Requirements	16
3.4.2	Summary of Findings by Street Corridor	17
4.0	TRANSITION PLAN DETAILS	25
4.1	City Official Responsible	26
4.2	Prioritized Recommendation for Transition Plan Phasing and Barrier Removal	26
4.3	Funding Opportunities and Alternatives	27
4.4	Initial Implementation Schedule	29
4.5	Conclusion and Next Steps	29
5.0	ASHLAND CITY GRIEVANCE PROCEDURE	30

List of Tables

Table 3.1.1:	Public Buildings-Interiors
Table 3.1.2:	Public Buildings-Parking Lots
Table 3.1.1:	Public Buildings-Sidewalks, Curb Ramps
Table 3.2.1:	Parks
Table 3.2.2:	Parks and Trailheads-Parking Lots
Table 3.2.3:	Parks and Trailheads-Sidewalks, Curb Ramps
Table 3.3:	Signalized Intersections
Table 4.2.1:	Preliminary Cost Estimate for Barrier Removal
Table 4.3.1:	Pedestrian Program Funding Opportunities
Table 4.4.1:	Initial Implementation Schedule

List of Figures

Figure 1: Ashland City Signalized Intersections Map

List of Appendices

Appendix A:	Facilities Inventory Self-Evaluation Requirements
Appendix B:	Detailed Self Evaluation Supporting Documentation
Appendix C:	Ashland City ADA Grievance Policy

ASHLAND CITY, TENNESSEE
AMERICAN WITH DISABILITIES ACT
FACILITIES INVENTORY SELF-EVALUATION AND TRANSITION PLAN

1.0 INTRODUCTION/PURPOSE

The Americans with Disabilities Act (ADA) is a federal civil rights law that prohibits discrimination against individuals with disabilities. Under Title II of the ADA 28 CFR 35.105, municipalities such as Ashland City, Tennessee must have a written plan of whether they comply with the requirements of ADA. Title II of The ADA requires that public agencies maintain an ADA Self-Evaluation and Transition Plan which details barriers identified and communicates an action plan for improving accessibility.

Ashland City began the process of reviewing administrative requirements (programs), internal policies, practices and services provided to the public. This part of the self-evaluation involves how policies and practices are implemented, with a determination of where programmatic modifications need to be made to ensure accessibility. In addition, Ashland City has initiated development of an ADA complaint procedure and designated at least one person who is responsible for overseeing ADA compliance.

As part of the self-evaluation process, Ashland City tasked CSR Engineering, Inc. (CSR) located in Pleasant View, Tennessee to conduct the facility inventory as it relates to public rights-of-way accessibility and to prepare a *Facilities Inventory Self-Evaluation Report*. Ashland City provided CSR with an initial facility inventory, related facility programmatic usage and public use activities for buildings and/or physical holdings, the pedestrian access routes and pedestrian circulation paths in the public right-of-way. Findings from the facility inventory will be utilized by Ashland City and the Ashland City ADA coordinator in the overall and ongoing programmatic review of the City's potentially discriminatory practices, policies or structural barriers towards individuals with disabilities.

The facilities self-evaluation inventory and subsequent report were developed based on the information presented in ADA Accessibility Guidelines for Buildings and Facilities (ADAAG), and the Proposed Guidelines for Pedestrian Facilities in the Public Right-of-Way (PROWAG).

Facilities evaluated are those buildings and/or physical holdings and the pedestrian access route and pedestrian circulation path in the public right-of-way as defined in both the ADAAG and PROWAG. Specifically, the types of facilities evaluated include: public access areas of buildings, recreational facilities, parking lots, sidewalks, curb ramps, driveway entrances that include ramps and traffic control signals and intersections. The *Facilities Inventory Self-Evaluation Report* identifies barriers to the accessibility of these facilities as defined by the ADA. The report contains a summary of the City's inventory of evaluated buildings, physical holdings and pedestrian facilities in the public right-of-way. The inventory includes measurements and observations collected for each type of facility. The measurement data was used to determine what barriers to accessibility exist and how severe each of those barriers is.

The self-evaluation of City programs and facilities inventory served as the basis to draft the *Ashland City ADA Facilities Inventory Self-Evaluation and Transition Plan*. Prioritizing the deficiencies and conflicts is an important element of the transition plan. A severity ranking was established based on the level of non-compliance and the impact of the barriers on the traveling public. Knowing what the challenges are and where they are located is only part of the information needed to have a plan. The City established a public outreach strategy, to ensure members of the community, especially those with disabilities, had an opportunity to be involved in the decision making. Through public information sessions and survey options, the City received input about the locations that are frequently visited and allowed the public to assist in developing the prioritization to these locations. These priorities along with were used to identify areas of high, medium and low priority. With this knowledge, the City can better plan to address areas with the most egregious problems balanced with the areas of highest use and importance. This plan will out how and when the City will upgrade facilities to achieve compliance with the ADA. When the plan is completed, the City will adapt a resolution to address the ADA barriers and be periodically updated as planned improvements are completed.

2.0 PEDESTRIAN FACILITY INVENTORY

Completing an inventory of all existing buildings, physical holdings and pedestrian facilities in the public right-of-way is the most significant component of the self-evaluation process. The data collected allows the City to determine whether any individual facility meets ADA requirements and to use the information to quantify the severity of defects which impact a facility's accessibility. An understanding of existing defects, combined with priorities expressed by the public, will ultimately serve as the basis to identify and prioritize locations that need accessibility improvements. Ashland City stakeholders such as the municipal departments and the public, after review of the *Facilities Inventory Self-Evaluation Report*, and the identified barriers to accessibility, provided input for prioritization and implementation for improvements. The prioritization method and schedule to complete improvements is included in the *Ashland City ADA Facilities Inventory Self-Evaluation and Transition Plan*.

The inventory-audit approach and process used to assess existing facilities was in compliance with guidelines presented in the ADAAG and PROWAG. In the spring of 2019, CSR field teams began collecting the data for the Ashland City facility inventory. The CSR teams evaluated building and exterior site features and all known pedestrian facilities located in the public right-of-way. The inventory included only those areas of each facility that are open to the public and employee common-use areas. CSR staff recorded, on specific facility forms, a multitude of characteristics and measurements needed to assess the ADA compliance of each. Characteristics were recorded such as lengths and slopes using tape measures and smart levels. For other characteristics, such as the type of traffic control at an intersection or sidewalk material, CSR staff simply observed and recorded the condition.

3.0 INVENTORY FINDINGS

This section includes a summary of identified barriers or deficiencies that hinder compliance with ADA guidelines for each type of facility inventoried. This summary is intended to help assess the state of Ashland City's network of buildings, physical holdings and public rights-of-way pedestrian facilities.

Many facilities that are fully ADA compliant in one measurement category are non-compliant in another. The *Ashland City Facilities Inventory Self-Evaluation and Transition Plan* addresses all of the facilities that are non-compliant in at least one measurement category.

Summary tables have been prepared for evaluated buildings, physical holdings and public rights-of-way pedestrian facilities as described in the Sections below. The tables present the architectural barriers/deficiencies identified. More detailed findings, by facility, are presented in Appendix B.

Facilities Inventory Self-Evaluation Requirements referenced by the ADA Accessibility Guidelines for Buildings and Facilities (ADAAG), and the Proposed Guidelines for Pedestrian Facilities in the Public Right-of-Way (PROWAG) are included within Appendix A.

3.1 Public Buildings

The following tables present the public buildings, associated parking lots, sidewalks and curb ramps inventoried for this study and the architectural barriers/deficiencies identified. Example photographs are provided in order to highlight the findings.

3.1.1 Public Buildings-Interior

The interiors of four public buildings or physical holdings were evaluated for ADA compliance. Facilities were selected included those clearly open to the public on a daily or continual basis or those specified by Department Directors as a location for public use or event on a non-continual basis. Public access areas such as entries, pathways, service counters, drinking fountains, restrooms, common areas and elevators were inventoried. Items reviewed included, but were not limited to, pathway widths, obstructions, ease of opening/closing doors, turning spaces, signage, safety features, component heights and depths, seating availability and table and bench dimensions. Table 3.1.1 presents a summary of CSR findings. Please refer to Appendix A for specific descriptions and illustrations.

As a result of Ashland City’s programmatic review, certain facilities were excluded from the inventory and therefore, omitted from the facility list provided to CSR. For example, the Fire Department and Water Processing Plant were not evaluated because they are not generally accessible to the public. Other facilities were not inventoried, at the City’s request, due to scheduled removal from public use or planned demolition. For example the City Hall and Fire Station #1 Complex was initially evaluated but later removed for the inventory due to the planned construction of a new complex. Any new replacement structures will include ADA design features.

Table 3.1.1-Public Buildings-Interior

Facility	Location	Observations
Fire Station #2	Fire Department	No public access to interior
Public Works, Parks & Police Complex	Police Dept. Waiting Room	Service Window counter exceeds 38" height

Facility	Location	Observations
	Parks Dept. & Public Works	Service Window counter exceeds 38" height
	Restrooms	No accessibility signage for 2 restrooms; No safety grab bar near toilets; stall door not self-closing
Water Processing Plant		No public access to interior
Senior Center		Compliant

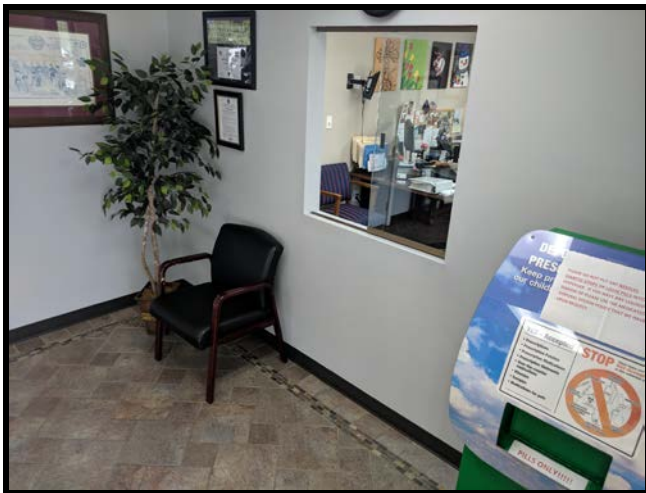

Police Dept. Window Counter Too High



Parks/PW Dept. Restroom, Non-Compliant Signage



Parks/PW Dept. Restrooms, No Safety Handle



Parks/PW Dept. Service Counter Too High

3.1.2 Public Buildings-Parking Lots

Exterior parking lots for the four facilities were surveyed for ADA compliance. Characteristics such as ADA parking space availability, number of spaces based on lot size, signage, widths, access aisles and proximity to building entry were evaluated. It should be noted that, for facilities that generally do not provide public access (fire Stations), parking lots were evaluated due to shared use between departments located nearby or if the parking lot had already been demarcated for ADA. Table 3.1.2 presents a summary of CSR findings.

Table 3.1.2-Public Buildings-Parking Lots

Facility	Location	Observations
Fire Station #2	Parking Lot	Signage is faded
Public Works, Parks & Police Complex	Parking Lot	Need 1 additional accessible space;
Water Processing Plant	Parking Lot	No signage
Senior Center		Compliant

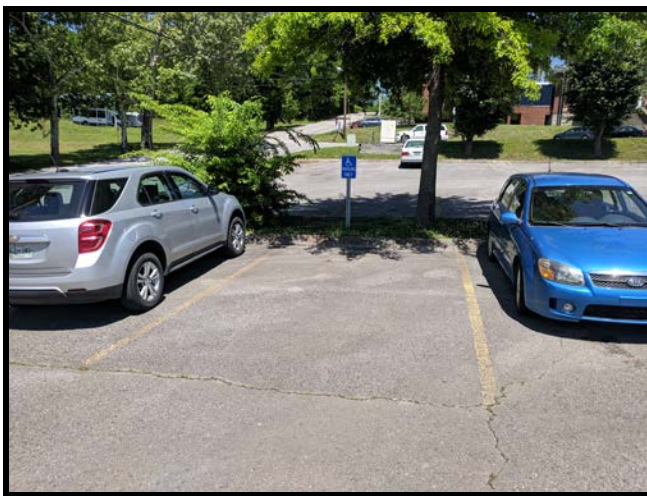

Example Non-Compliant Space

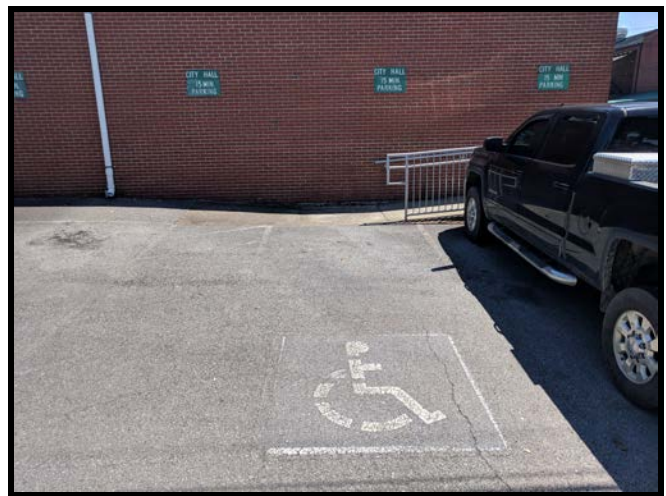

Example Faded or No Signage

3.1.3 Public Buildings-Sidewalks, Curb Ramps

CSR evaluated existing pedestrian facilities (sidewalks and curb ramps) at each of the four Ashland City facilities. For sidewalks, required compliance characteristics for width, surface conditions, changes in level (discontinuities), slopes and obstructions were identified. For ramps, CSR measured similar characteristics as well as for turning spaces and detectable warnings. Specific PROWAG criteria is presented in Appendix A. Table 3.1.3 presents a summary of CSR findings.

Table 3.1.3-Public Buildings-Sidewalks, Curb Ramps

Facility	Location	Observations
Fire Station #2		Compliant
Public Works, Parks & Police Complex	Ramp to Sidewalk	Running slope >8.3%
	Sidewalk	Multiple discontinuities along 152' length; landscape obstructions
Water Processing Plant		Compliant
Senior Center		Compliant



Police, Parks & PW Ramp and Sidewalk Deficiencies

3.2 Parks and Trailheads

The following tables present the public parks, trailheads and recreational facilities, associated parking lots, sidewalks and curb ramps inventoried for this study and the architectural barriers/deficiencies identified. It should be noted that the individual pedestrian trails and greenways were not evaluated during the self-evaluation. The Tennessee Department of Environment and Conservation published a Greenway and Trails Program, ADA Accessibility Guideline that specifically excludes trails from ADA compliance unless they are new construction, altered or upgraded or lengthened to connect to an already accessible trail. Example photographs of the public parks, trailheads and recreational facilities are provided in order to highlight the findings.

3.2.1 Parks and Trailheads

Six Ashland City parks, trailheads or recreational facilities were evaluated for ADA compliance. Generally, trailheads are comprised of parking areas and connectors to the trails and are therefore addressed in the sections to follow. For the remaining facilities with physical structures, public access areas such as entries, pathways, service counters, drinking fountains, restrooms, common areas and elevators,

concessions, playgrounds, recreational fields and courts were inventoried. Items reviewed included, but were not limited to, pathway widths, obstructions, ease of opening/closing doors, turning spaces, signage, safety features, component heights and depths, seating availability and table and bench dimensions. Table 3.2.1 presents a summary of CSR findings. Please refer to Appendix A for specific descriptions and illustrations.

Table 3.2.1-Parks

Facility	Location	Observations
Cumberland River Bi-Centennial Trail	Eagle Pass Section-Trail	Upgrade to ADA only if altered or new
	Sycamore Ridge Section-Trail	Upgrade to ADA only if altered or new
	Marks Creek Section-Trail	Upgrade to ADA only if altered or new
Caldwell Nature Area	Entrance	No ADA accessible parking, access or facility amenities.
911 Memorial Park	Restrooms	Discontinuity at Thresholds
J.W. Johns Jr. Park	Pavilion w/Concessions & Restrooms	Ramp to restrooms Running Slope >8.3% Restroom door opening <32"
	Dugouts/Bleachers/Fields	No ADA access
	Playground near Mulberry St.	Discontinuities entering play area Restricted accessible play area due to mulch covering
Riverbluff Park	Main Pavilion and Play Area	Compliant
John C. Poole Recreation Area	Tennis Courts	No ADA access
	Observation Area	Tables and benches not accessible



Caldwell Park Non-Accessible



J.W. Johns Jr. Restroom Ramp Slope



J.W. Johns Jr. Dugouts & Bleachers Non-Accessible

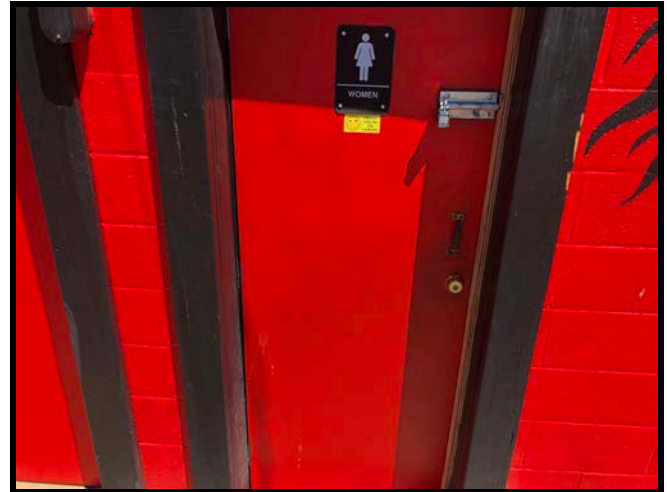

J.W. Johns Jr. Restroom Door Too Small



John C. Poole Tennis Observation Area Non-Accessible



J.W. Johns Jr. Playground, Mulch Restricts Accessibility

3.2.2 Parks and Trailheads-Parking Lots

Exterior parking lots for the six parks, trailheads or recreational facilities were surveyed for ADA compliance. Characteristics such as ADA parking space availability, number of spaces based on lot size, signage, widths, access aisles and proximity to building entry were evaluated. Table 3.2.2 presents a summary of CSR findings.

Table 3.2.2-Parks and Trailheads-Parking Lots

Facility	Location	Observations
Cumberland River Bi-Centennial Trail	Eagle Pass Trailhead Parking	No ADA accessible spaces
	Sycamore Ridge Trailhead Parking	No ADA accessible spaces
	Marks Creek Trailhead Parking	Compliant
Caldwell Nature Area	Parking Lot and Entrance	No ADA access for parking, entrance or facility amenities.
911 Memorial Park	Parking Lot	No signage
J.W. Johns Jr. Park	Parking Lot	Access Aisle on 4' Three spaces but only 2 signs
Riverbluff Park	Parking Lot	Need 1 additional accessible space
John C. Poole Recreation Area	Parking Lot	Access Space and Aisle Non-Compliant



Bicentennial Trail Parking Non-Accessible



911 Memorial Park, No Signage



J.W. Johns Jr. Access Aisle & Signage Non-Compliant



John C. Poole Parking Space & Aisle Non-Compliant

3.2.3 Parks and Trailheads-Sidewalks, Curb Ramps

CSR evaluated existing pedestrian facilities (sidewalks and curb ramps) at each of the six parks, trailheads or recreational facilities. For sidewalks, required compliance characteristics for width, surface conditions, changes in level (discontinuities), slopes and obstructions were identified. For ramps, CSR measured similar characteristics as well as for turning spaces and detectable warnings. Specific PROWAG criteria is presented below in Section 3.4. Table 3.2.3 presents a summary of CSR findings.

Table 3.2.3-Parks and Trailheads-Sidewalks, Curb Ramps

Facility	Location	Observations
Cumberland River Bi-Centennial Trail	Eagle Pass Trailhead Parking	Ramp from parking lot to Trailhead, Running slope >8.3%
	Sycamore Ridge Trailhead Parking	No Crosswalk on Chapmansboro Rd., No Access to trail
	Marks Creek Trailhead Parking	Compliant
Caldwell Nature Area	Parking Lot and Entrance	No ADA accessible areas
911 Memorial Park	Parking Lot Entrance to Play Area	Discontinuity entering play area
	Connector from Play Area to Restrooms	Obstruction/Overgrowth
J.W. Johns Jr. Park	Playground Near Mulberry St.	Discontinuities entering play area
Riverbluff Park	Main Pavilion and Play Area	Sidewalk abruptly ends; Ramp/Path slope from pavilion to play area non-compliant.
John C. Poole Recreation Area	Parking Lot	Compliant



Bicentennial Trail Eagle Pass Trailhead-Ramp Slope



911 Memorial Park Connector Overgrowth



Riverbluff Park, Sidewalk End



Riverbluff Park, Ramp to Play Area Slope

3.3 Signalized Intersections

Ashland City is responsible for the operation and maintenance of three (3) signalized intersections. At intersections where there are pedestrian signals, the signals should meet accessibility standards. In general, accessible intersections should have pedestrian push buttons placed to activate the signals within easy reach of pedestrians who are intending to cross each crosswalk. It should be obvious which push button is associated with each crosswalk. Also, the poles for push buttons should be in optimal locations for installation of accessible pedestrian signals.

Both PROWAG and the Manual on Uniform Traffic Control Devices (MUTCD) define an *Accessible Pedestrian Signal* as a device that communicates information about pedestrian timing in non-visual format. Examples include audible tones, verbal message or vibrating surfaces.

In general, an intersection should have the following:

- Two push buttons on two separate poles (one for each crossing direction) 10 feet apart to easily distinguish which pedestrian signal is being activated or, audible signals if the push buttons are located on the same pole.
- A push button that meets the standard i.e. large enough that it can be activated with a fist and not requiring significant force to push.

The CSR Field Teams evaluated the pedestrian signal equipment, street crossings, path of travel to the signals, curb ramps and adjacent clear spaces at each of the three intersections. It should be noted that CSR only evaluated those MUTCD pedestrian signal requirements that pertain to ADA compliance only.

Figure 1 presents the three intersections evaluated by CSR. Table 3.3 presents a summary of observations and deficiencies, identified at each of the signalized intersections. Example photographs of the Signalized Intersections are provided below in order to highlight the findings.

Figure 1: Ashland City Signalized Intersections Map



The three signalized intersections were evaluated based on each pedestrian corner installed with an intended or implied street crossing.

1. Main Street and Cumberland – 3 corners or 6 crossing directions
2. Main Street and Highway 49/Frey Street – 3 corners or 6 crossing directions, An additional pedestrian crossing for the Courthouse Parking entrance was evaluated and included with this location.
3. Main Street and Stratton/Elizabeth – 4 corners or 8 crossing directions

Table 3.3-Summary of Signalized Intersections Findings

Metric	1: Main St. & Cumberland	2: Main Street & HWY 49	3: Main Street & Stratton
Ramp Types	2 Parallel, 4 Perpendicular	2 Parallel, 4 Perpendicular	5 Parallel, 3 corners with no Ramps
Turning Space Size	2 Ramps too small (3x5)	2 Ramps too small (3x5)	3 Ramps too small (3x5)
Turning Space Running Slope	Compliant	3 Ramps exceed 2%	3 Ramps exceed 2%
Ramp Running Slope	Compliant	1 Ramp exceeds 8.3%	4 Ramps exceed 8.3%
Ramp Flares	Compliant	6 Flares exceed grade	None installed
Width of Ramp & Turning Space	2 Ramps too small (<4')	6 Ramps too small (<4')	5 Ramps too small (<4')
Grade Break	Compliant	Compliant	N/A
Cross Slope	2 Ramps exceed grade (>2%)	3 Ramps exceed grade (>2%)	Compliant
Gutter Counter Slope	Compliant	Compliant	Compliant
Space Beyond Grade Break	Compliant	Compliant	Compliant
Detectable Warning	All 6 Detectable Warning Surfaces deficient	All 8 Detectable Warning Surfaces deficient	4 Detectable Warning Surfaces deficient
Crosswalk Lines	Compliant	Compliant	Only 1 crosswalk installed
Pushbutton (PB) at Each End of Crosswalk	2 corners without pushbuttons	2 corners without pushbuttons, 4 corners without one at each end	4 corners without pushbuttons, 2 corners without one at each end
PB Adjacent to All Weather Surface	Existing are compliant	1 PB located on street side of pole directly above curb	Existing are compliant
PB Location and Distance	3 pushbuttons are >4' from crosswalk	4 pushbuttons are >4' to >30' from crosswalk	1 pushbutton is >4' from crosswalk
PB Wheelchair Accessible Route	Existing are compliant	1 crosswalk without wheelchair access.	Existing are compliant
PB Distance to Curb	1 pushbutton >6' from curb	1 PB located on street side of pole directly above curb	Existing are compliant
PB Parallel to Crosswalk	Existing are compliant	1 PB located on street side of pole directly above curb	Existing are compliant
PB Height Appx. 4'	Existing are compliant	Existing are compliant	Existing are compliant
PB Distance from Clear Space	1 pushbutton >10' from Clear	1 pushbutton >10' from Clear	Existing are compliant

Metric	1: Main St. & Cumberland	2: Main Street & HWY 49	3: Main Street & Stratton
	Space	Space	
Multiple Pushbuttons <10' Apart	Existing are compliant	Existing are compliant	Existing are compliant
Locator Tone	None or n/a	None or n/a	None or n/a
Tactile Arrow	None or n/a	None or n/a	None or n/a
Speech Walk Message	None or n/a	None or n/a	None or n/a
Speech Pushbutton Info Message	None or n/a	None or n/a	None or n/a
Audible and Walk Indicator	None or n/a	None or n/a	None or n/a
General Notes	<p>1 Signal Pole constructed in Ramp, 1 Visual Indicator not working 1 PB not functioning 1 Arrow pointing in wrong direction</p>	<p>1 PB not accessible No signage for 1 PB Rhea Alley Signal location needs relocated.</p>	<p>4 intended crossings do not have Ramps installed 2 intended crossings have Ramps but no Crosswalk. 1 location has PB but no Ramps or Crosswalk.</p>



Main St. and Cumberland
Pole in Ramp, Deficient Detectable Warning Surface



Main St. and HWY 49/Frey St.
Pushbutton on Street Side and >30' from Crosswalk

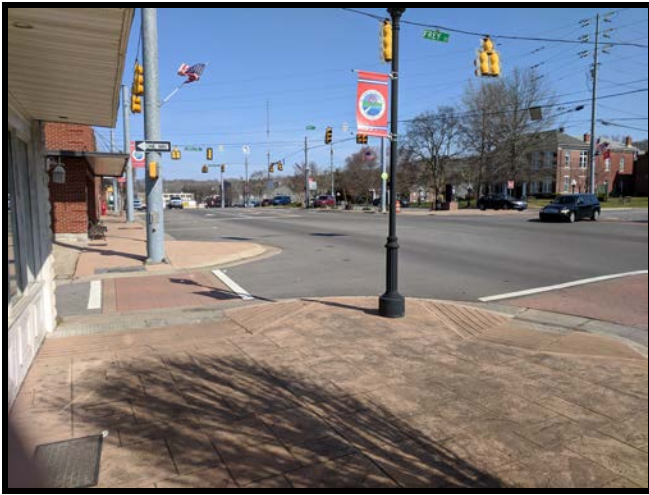

**Main St. and HWY 49/Frey St.
Signal Pole for 2 Crossings across Rhea Alley**



**Main St. and HWY 49/Frey St.
Excessive Flare Grades, Courthouse Entrance Drive**



**Main St. and Stratton/Elizabeth
Signal Pole without ramp or Crosswalk**



**Main St. and Stratton/Elizabeth
Deficient DWS, Ramp with no Crosswalk**

As indicated by the survey results of the three signalized intersections, all have significant needs for replacement or upgrades to meet ADA compliance. With deficiencies also identified by the sidewalk evaluation, the intersection at Main Street and Cumberland will require pole relocation or sidewalk widening to correct obstruction and width issues as well as to improve the pedestrian crossing pushbutton locations, ramp grades and detectable warning surfaces. The Main Street and Stratton/Elizabeth Street intersection will also require upgrades on all four corners for ramp installations, crosswalk painting, pushbutton compliance and detectable warning surfaces.

The PROWAG provides clear instruction (requirement R209.2) that pedestrian signals should only be altered or improved when new signal or pole construction is planned. This includes signal controller,

software or signal head replacement. This does not prohibit sidewalk or path access improvements or installation of new pushbuttons.

3.4 Pedestrian Facilities within the Public Right-Of-Way

To help assess the state of Ashland City's maintained sidewalk corridors, CSR evaluated over 1.6 miles of pedestrian pathways within 14 street corridors. This portion of the self-evaluation included sidewalks, curb ramps, driveway entrances which are within the pedestrian path, and crossings at un-signalized intersections. The supporting narrative presented in the sections below provide a summary of observations and deficiencies for the measured metrics for sidewalk pathways at each of the evaluated corridors. Example photographs of the observations are provided below in order to highlight the findings.

3.4.1 Pedestrian Pathways Summary of Requirements

The technical provisions of the PROWAG provide multiple elements for pedestrian pathways in the public right-of-way. Please refer to Appendix A for specific descriptions and illustrations. The CSR Field Teams traversed each pathway and measured and documented each noted barrier/deficiency for the following:

- Width: 4' minimum, exclusive of curb; 5' preferred, if less than 5' passing spaces must be provided every 200'.
- Running Slope (Grade): shall not exceed >5% unless grade of adjacent street is over 5%.
- Cross Slope: shall be 2% maximum.
- Surface Condition: shall be firm and stable, slip resistant. Vertical discontinuities (changes in level) shall be ½" maximum; with those between ¼" and ½" being beveled. Horizontal openings, such as grates and joints may not exceed ½".
- Obstructions and Protrusions: disallows passable sidewalk space of less than 4' for more than 24" maximum length. If less 24" path may reduce to 32" minimum. Leading edges between 27" and 80" above the finished surface cannot protrude more than 4" horizontally into the path. (utility poles, hydrants, mail boxes, vegetation, signs, furniture).
- Curb Ramp Width: shall be 4' minimum.
- Curb Ramp Running Slope: shall be no steeper than 8.3%.
- Curb Ramp Cross Slope: shall be 2% maximum.
- Curb Ramp Landings/Turning Spaces: shall be minimum of 4' by 4' or 4' by 5' if constrained.
- Ramp Flares: shall not exceed 10% maximum.
- Ramp Grade Breaks and Clear Space: breaks should be perpendicular to direction of ramp and flush. Clear space beyond the bottom grade break should be 4' by 4' minimum.

- Detectable Warnings: shall extend 2' minimum in the direction of pedestrian travel and extend the full width of the ramp; contrast in color to adjacent path or ramp; dome integrity shall be maintained.
- Ramp Obstructions, Protrusions, Vertical Discontinuities, Horizontal Openings: shall maintain 4' minimum width and are subject to sidewalk guidelines for same.

3.4.2 Summary of Findings by Street Corridor

Vantage Point Road: No deficiencies were identified along the 345' of pathway.

Little Marrowbone Road:

Sidewalk Side	Start/End/Location	Deficiency Type	Deficiency Notes/Observations
East	Start of Sidewalk - Near Park	Discontinuity	No transition to grassed area
East	Driveway 1 from HWY 12-Sidewalk Ramp	Ramp Slope	Running slope (both sides) >8.3%
East	Driveway 1 from HWY 12-Sidewalk Ramp	Cross Slope	Cross slope (both sides) >2.0%
East	Driveway 3 from HWY 12-Both Sides	Discontinuity	>1/4" both sides transition concrete to asphalt
East	2-feet NE from Driveway 3	Obstruction	Utility Pole within 5.0 foot sidewalk route
East	20.5 feet NE from Driveway 3	Discontinuity	>1/4"
East	End of Sidewalk - Past Driveway 3	Discontinuity	No transition to grassed area

Cumberland Street:

Sidewalk Side	Start/End/Location	Deficiency Type	Deficiency Notes/Observations
North	Side of McCoy Building	Slope/Grade	Running slopes >5.0%
North	On-Street Handicap Parking-Side of McCoy Bldg.	Handicap Access	Aisle/ramp not provided
South	69 feet SW of Main Street	Obstruction	Water valve and concrete steps
South	Fitness Center including Alley Crossing to Ramp-105' length of section	Discontinuity	>1/4" entire length of section, cracks, transitions and slopes
South	On-Street Handicap Parking-Main & Cumberland	Handicap Access	Aisle/ramp not provided

North Vine:

Sidewalk Side	Start/End/Location	Deficiency Type	Deficiency Notes/Observations
North	Rhea Street and 10 Feet N of Rhea Street	Discontinuity/Obstruction	>1/4", two > 4.0" sidewalk step-ups
North	Church of Christ HC Ramp to Vine Street Sidewalk	Detectable Surface	No detectable warning surface present on Ramp to Street

Rhea Alley:

Sidewalk Side	Start/End/Location	Deficiency Type	Deficiency Notes/Observations
North	Back of Heritage Bank	Discontinuity/Obstruction	>1/4", two > 10.0' sidewalk step-ups

Frey Street (SR 49):

Sidewalk Side	Start/End/Location	Deficiency Type	Deficiency Notes/Observations
South	Segment 1: Front of Children's Services Department	Discontinuity	>1/4" at start of sidewalk ramp; No Guard at end-step down to grass
South	Segment 2: Main Street to 114 Frey Street-108 Frey	Discontinuities (2)	>1/4", crack (2)
South	Segment 2: Main Street to 114 Frey Street-106 Frey	Discontinuity	>1/4", crack
South	Segment 2: Main Street to 114 Frey Street-Start of Sidewalk	Discontinuity	>1/4", transition to Asphalt
North	Segment 3: Main Street to Court Street-207' East of Main	Slope/Grade	Running slopes >5.0%
North	Segment 3: Main Street to Court Street-10' West of Court	Slope/Grade	Running slope > 5.0%
North	Segment 3: Main Street to Court Street-Side of County Bldg.	Obstructions	Gutter downspouts & PVC cleanout cap

Ruth Drive:

Sidewalk Side	Start/End/Location	Deficiency Type	Deficiency Notes/Observations
North	100 Feet from Sidewalk Start NE of Main St to	Obstruction	Utility pole in sidewalk edge
North to West	Sidewalk Curve from NE to North	Discontinuities	Multiple cracks throughout sidewalk curve
North to West	All Ramps and Driveways on Ruth Street	Ramp Slope	Running slope (both sides) >8.3%
North to West	All Ramps and Driveways on Ruth Street	Cross Slope	Cross slope (both sides) >2.0%

Sycamore Street:

Sidewalk Side	Start/End/Location	Deficiency Type	Deficiency Notes/Observations
North	N Main Past Lloyd Harris Bonds		Compliant
South	N Main to Parking Lot Driveway-142' length of pathway	Width	Entire length < 4.0 feet
South	N Main Ramp to Sidewalk	Ramp Discontinuity	Discontinuity: cracked

Court Street:

Sidewalk Side	Start/End/Location	Deficiency Type	Deficiency Notes/Observations
West	Frey Street to Sycamore Street	Width	Varying widths with over 60 feet < 4.0 feet,
West	On-Street Handicap Parking	Handicap Access	Aisle/ramp not provided

Stratton Boulevard:

Sidewalk Side	Start/End/Location	Deficiency Type	Deficiency Notes/Observations
North	S Main to 1st Driveway on Left-73' of segment	Width	Entire length < 4.0 feet
North	Last 37 feet to Driveway-37' length of pathway	Discontinuities	>1/4" entire length of section, cracks, gravel
South	S Main to 1st Driveway on Right		Compliant

Helen Street:

Sidewalk Side	Start/End/Location	Deficiency Type	Deficiency Notes/Observations
South	S Main to Duke Street-248' length of pathway	Width	Entire length < 4.0 feet, overgrown, disrepaired areas
South	45 feet NE of Fire Hydrant	Discontinuity	>1/4"
South	Driveway Sidewalk Ramps (2)	Ramp Slope	Running slopes >8.3%
South	Driveway Sidewalk Ramps (2)	Cross Slope	Cross slope >2.0%, <4.0 width

Duke Street:

Sidewalk Side	Start/End/Location	Deficiency Type	Deficiency Notes/Observations
West	106 Duke Street Parking Entrance to Helen Street-124' length of pathway	Width	Entire length < 4.0 feet, overgrown, disrepaired areas
West	106 Duke Street Parking Entrance - Sidewalk Ramp (Driveway)	Ramp Slope	Running slope >8.3%
West	106 Duke Street Parking Entrance - Sidewalk Ramp (Driveway)	Cross Slope	Cross slope >2.0%, <4.0 width

Elizabeth Street:

Sidewalk Side	Start/End/Location	Deficiency Type	Deficiency Notes/Observations
West	S Main to Elementary School Drive-338' length of pathway	Discontinuities	Entire length of section, cracks, gravel, broken
West	Elementary School Drive to Lowe Street	Width	Handicap 5 x 5 passing spaces not provided every 200' (SW width <5.0')
West	149 feet South of Fire Hydrant	Discontinuity	>1/4"
East	North of Lowe Street-Sidewalk Section and Ramp-Funeral Home-65' length of pathway	Discontinuities	Entire section needs replaced-cracks

Main Street/HWY 12:

Sidewalk Side	Start/End	Location Specifics	Deficiency Type	Deficiency Notes/Observations
East	Forrest Street to Helen Street	684' length of pathway	Cross Slope	>2% entire segment length
East	Forrest Street to Helen Street	684' length of pathway	Width:	Handicap 5 x 5 passing spaces not provided every 200' (SW width <5.0')
East	Forrest Street to Helen Street	Culvert Crossing 16' N of Forrest	Width	Reduces to 3' 3" for 8-foot length
East	Forrest Street to Helen Street	End of Culvert Crossing	Discontinuity	>1/4"
East	Forrest Street to Helen Street	64' N of Culvert Crossing	Discontinuity	>1/4"
East	Forrest Street to Helen Street	Between Sonic Drives	Discontinuity	>1/4" , cracked and broken above water line
East	Forrest Street to Helen Street	End of Sidewalk at Helen Street	Discontinuity	>1/4" , cracked
East	Forrest Street to Helen Street	S Driveway to Rite Aid	Ramp	No rightsideramp, cross slope >2.0%
East	Forrest Street to Helen Street	N Driveway to Rite Aid	Ramp	No left sideramp, cross slope >2.0%
East	Forrest Street to Helen Street	S Driveway to Sonic	Ramps	Both sides are less than 4.0', cross slopes >2.0%

Sidewalk Side	Start/End	Location Specifics	Deficiency Type	Deficiency Notes/Observations
East	Forrest Street to Helen Street	N Driveway to Sonic	Ramp	Right ramp cross slope >2.0%
East	525 S. Main to Turner Street	159' length of pathway		Compliant
East	Turner Street to Advanced Auto Driveway	4' N of Turner Street	Discontinuity	>1/4" , Cracked
East	Turner Street to Advanced Auto Driveway	40' N of Turner Street, storm grate	Discontinuity	>1/4" , Cracked
East	Boyd Street to 395 S. Main	Start of Segment at Boyd Street	Discontinuity	No transition to grassed area /Boyd Street
East	395 S. Main to Stratton Street	30' S of 315 Main Street	Discontinuity	>1/4"
East	395 S. Main to Stratton Street	Ramps at Walgreens Driveway	Ramps	Grade breaks not perpendicular to ramp direction
East	Stratton Street to King Automotive Trucks	292' length of pathway	Width	Entire length < 4.0 feet,
East	Stratton Street to King Automotive Trucks	Ramp to King Auto	Discontinuity	>1/4" , Width
East	107 S. Main to Frey Street	178' length of pathway		Compliant
East	Frey Street to Sycamore Street Fronting Court House Complex		Obstructions	Three Signal Poles; Three Lamp Posts reducing Width and passing
East	Frey Street to Sycamore Street Fronting Court House Complex	Cumberland St. Crossings	Obstructions	Ramps to Cumberland St Crossings blocked
East	Sycamore Street to Shell Driveway	157' length of pathway		Compliant
West	Low Street to N. of Pinnacle Bank Drive	207' length of pathway		Compliant
West	Cheatham Lake Condos to Elizabeth Street	Hardee's to Gorilla Muffler-470'	Width	Handicap 5 x 5 passing spaces not provided every 200' (SW width <5.0')
West	Cheatham Lake Condos to Elizabeth Street	30' N. of Boyds Funeral Home	Discontinuity	>1/4"

Sidewalk Side	Start/End	Location Specifics	Deficiency Type	Deficiency Notes/Observations
West	Cheatham Lake Condos to Elizabeth Street	Front of Hardees	Obstruction/Discontinuities	>1/4", Meters and Valves
West	Cheatham Lake Condos to Elizabeth Street	Start of Segment at Condos	Ramp	Running slope >8.3%, Cross Slope >2.0%, Break not Perpendicular
West	Cheatham Lake Condos to Elizabeth Street	Front of Gorilla Mufflers	Obstruction	Utility Pole
West	Elizabeth Street to Chestnut Street	Cheatham Co. Clerk's Office Drive	Discontinuity	>1/4" between drive and sidewalk
West	Chestnut Street to Cumberland Street	On-Street Parking	Handicap Access	None
West	Cumberland Street to Mulberry Street	337' length of pathway		Compliant
West	212 N. Main Street	43' length of pathway		Compliant



**Little Marrowbone Rd.
Utility Pole Obstruction**



**Cumberland Street-On Street Parking
No Accessible Aisle or Ramp from Space**



North Vine Street- Changes of Level, Step-ups



HWY 49/Frey Street- Typical Discontinuity >1/4"



Ruth Street- Cracked Sidewalk and Cross Slope >2%



Helen Street- Typical Obstruction Due to Overgrowth



Duke Street- Running Slope of Ramp >8.3%



Elizabeth Street- Discontinuities along Entire Path



Main Street/HWY 12-Utility Poles Obstructing Path/Ramps



Main Street/HWY 12-Typical Discontinuity >1/4"



**Main Street/HWY 12
Utility Pole Obstruction and No Clear Path**



**Main Street/HWY 12
No Accessible Ramp, Slope Exceedance/DWS Misplaced**

4.0 TRANSITION PLAN DETAILS

The detailed findings of this facilities self-evaluation make it clear that there are deficiencies in many existing pedestrian facilities in Ashland City’s public rights-of-way. These deficiencies create significant barriers to access for many community members with disabilities.

Ashland City is committed to creating a more accessible pedestrian transportation network for all members of the community. To address the deficiencies identified in this report, Ashland City has developed the *ADA Facilities Inventory Self-Evaluation and Transition Plan* for Public Rights-of-Way. Title II of the Americans with Disabilities Act 28 CFR 35.150(d) sets forth the requirements for this plan. This plan will identify noncompliant pedestrian facilities that limit accessibility, describe how these barriers

to access will be corrected, specify a schedule for achieving compliance, and designate an official responsible for implementing the plan. It should be noted that not all barriers must be removed to provide program access. The highest priority is to remove those barriers that limit access to city programs or present safety concerns.

4.1 City Official Responsible

The ADA Coordinator is responsible for ensuring that Ashland City’s programs, services, and activities are accessible to and usable by individuals with disabilities. The City’s ADA Coordinator is:

Brian Stinson
Town of Ashland City
101 Court Street
Ashland City, TN 37015

Phone: 615-792-6455
E-mail: bstinson@ashlandcitytn.gov

Days/Hours Available
Monday-Friday/8:00 a.m. – 4:00 p.m.

For questions regarding the ADA Transition Plan, or to request an ADA accommodation or file an ADA complaint, please contact the ADA Coordinator.

4.2 Prioritized Recommendation for Transition Plan Phasing and Barrier Removal

Ashland City will begin a phased implementation of the recommended correction or removal of the identified physical barriers. Funding limitations will prevent all facilities from immediately becoming fully compliant with ADA standards. Therefore, a phased approach will be implemented based on an evaluation of level of use by the public, complexity of the correction and readily available City manpower to implement barrier repairs and removals. Priority will be given to ensure that all programs provided to the public are accessible in some manner.

The following tables represent the cost estimates of findings to remove the barriers identified. The cost estimates reflect planning level estimates at the time of assessment. Actual costs can only be firmly determined via standard design and construction process. The Town of Ashland City may choose to modify priorities to allow flexibility in accommodating community requests, petitions for reasonable modifications from persons with disabilities, changes in City programs, ongoing evaluation and funding constraints and opportunities.

It is not financially feasible to remove all barriers to access immediately. It is the goal of the *Ashland City ADA Facilities Inventory Self-Evaluation and Transition Plan* to provide access to the programs, activities and services provided by the City. Ashland City has on-going programs that monitor proposed alteration

projects and include the review of the various accessibility concerns identified, in order to bring facilities to current ADA standards when projects take place. The City plans to remove barriers over time, as indicated by the Implementation Schedule (presented below). Sidewalk corridors, trails, buildings and parks identified barriers will be addressed based on their priority by the City and with available funds.

Initial phasing of corrections and removal of barriers, as identified by the City are as follows:

- Phase 1: Public Works, Parks and Police building,
All signage and striping for parks and other facilities
- Phase 2: Sidewalks and entrances to playgrounds or trails, tennis Courts
- Phase 3: Sidewalks and Intersections along the Main Street/Highway 12 Corridor,
J.W. Johns Jr. Park
- Phase 4: Secondary Street/Residential Sidewalks

The following tables summarize the estimated costs for addressing improvements. Note that estimates provided are based on current TDOT unit price guides and costs to complete similar projects. Totals per Facility item are based on detailed task items presented above in Section 3.0 (Inventory Findings). Pricing estimates should be evaluated after five years and may not reflect actual cost at the time of repair.

Table 4.2.1-Preliminary Cost Estimate for Barrier Removal

Facility	Description	Preliminary Cost Estimate
Public Works, Parks & Police Interiors	Table 3.1.1 Deficiencies	\$4,400.00
Public Works, Parks & Police Sidewalk, Curbs & Ramps	Table 3.1.3 Deficiencies	\$1,200.00
Signage and Striping for Building	Table 3.1.2 Deficiencies	\$900.00
Signage and Striping for All Parks	Table 3.2.2 Deficiencies	\$5,700.00
Parks, Trails & Playground Sidewalks, Curbs & Ramps	Table 3.2.3 Deficiencies	\$5,800.00
J.W. Johns Jr. Park Sidewalks, Curbs & Ramps, Accessibility, Replacement of Park Components	Tables 3.2.1, 3.2.2 & 3.2.3 Deficiencies	\$8,200.00
Highway 12/Main Street Sidewalks, Curbs, Ramps, Drives	Tables 3.4.2 Deficiencies	\$70,800.00
Highway 12/Main Street Intersections and Signals	Table 3.3 Deficiencies	\$120,000.00
Secondary Streets Sidewalks, Curbs, Ramps and Drives	Tables 3.4.2 Deficiencies	\$143,000.00

4.3 Funding Opportunities and Alternatives

Current funding for ADA barrier removal will be initially funded through the existing budget process and funds, pulling from several departments. However, Ashland City will take full advantage of various

funding opportunities that may come available for ROW accessibility improvements. These include applying for funds at the federal and state levels, local options and partnering with private options. Funding may include sources such as:

- TIGER - BUILD Transportation Discretionary Grants
- TIFIA - Transportation Infrastructure Finance & Innovation Act
- BRI – Bridge-Highway Bridge Replacement and Rehabilitation (HBRRP)
- FTA - Federal Transit Capital, Urban & Rural Funds
- ATI - Associated Transit Improvement
- CMAQ - Congestion Mitigation/Air Quality Program
- HSIP - Highway Safety Improvement Program
- NHPP - National Highway Performance Program
- SRBG - Surface Transportation Block Grant Program
- TA - Transportation Alternatives Set-Aside
- RHC - Railway-Highway Crossing Program
- RST - Road Safety and Technology
- RTP - Recreational Trails Program
- SRTS - Safe Routes to School
- PLAN - Statewide Planning & Research or/Metropolitan Planning Funds
- NHTSA 402/405 - State & Community / National Priority Safety Programs
- FLTTP - Federal Lands & Tribal Transportation Programs

The City may explore partnerships to fund accessibility utilizing state and federal grants. Allocation of annual departmental budgets, maintenance funds, special taxing districts, already scheduled/funded Capital Improvement Program (CIP) projects, bond funds, Community Development Block Grant (CDBG) Funds and Highways User Revenue Funds may be other sources for projects as well as private funds from foundations, private development, and private individuals.

Table 4.3.1-Pedestrian Program Funding Opportunities

Federal Funding Sources	Curb Ramps	Signals	Sidewalk	Crosswalks	Trails	Safety	Training
TIGER BUILD	•	•	•	•	•		
TIFIA	•	•	•	•	•		
FTA	•	•	•	•			
ATI	•	•	•	•			
CMAQ	•	•	•	•	•		•
HSIP	•	•	•	•	•		•
NHPP	•	•	•	•	•		
SRBG	•	•	•	•	•	•	•
TA	•	•	•	•	•	•	•
RHC			•				
RST		•					
RTP	•		•	•	•		•
SRTS	•	•	•	•	•	•	•
PLAN						•	•
NHTSA 402/405						•	•
FLTTP	•	•	•	•	•		

4.4 Initial Implementation Schedule

Because Ashland City has many rights-of-way locations, parks, and facilities, it is not possible to remove all barriers immediately. Barriers will be removed systematically, citywide, to ensure equality among City programs. It is the intent of the City to address barriers to accessibility over 20 years, contingent upon City Council approval, depending on the immediate necessity, degree of complexity, and overall cost.

Ashland City reserves the right to modify barrier removal priorities to allow flexibility in accommodating community requests, petitions for reasonable modifications from persons with disabilities, changes in City programs, on-going evaluations and funding constraints and opportunities.

The list below is based on the locations evaluated in the ADA Self-Evaluation. It will be amended as additional self-evaluation is completed. In addition to CIP programs, other development initiatives will include opportunities to provide ADA compliance. The City intends to apply an annual approved budget with ADA remediation components built into the budget, subject to City Council approval. The following table provides schedules for implementation of the barriers identified in this report, subject to adjustment.

Table 4.4.1- Initial Implementation Schedule

Facility	Preliminary Cost Estimate	Implementation Schedule (Years)	Approximate Annual Budget*
All Buildings & Parks, Parking, Signage, Access, Sidewalks, Curbs and Ramps, Park Components, Highway 12 and Secondary Street Sidewalks and Drives	\$360,000.00	20	\$12,000-\$15,000

*Annual Budget/Funding will be evaluated as additional ADA barrier removal sources become available

4.5 Conclusion and Next Steps

In developing the *Ashland City ADA Facilities Inventory Self-Evaluation and Transition Plan*, facilities, programs, procedures, services, and activities were reviewed. The recommended barrier corrections and removals were prioritized and an implementation plan was developed to provide guidance for the City’s improvement projects in the coming years. The City is taking the actions referenced herein and will continue to look for and remedy barriers to access to ensure that Ashland City citizens who are disabled are given access to the City’s programs, services, and activities. Several initial steps can be taken immediately to address barriers. Ashland City will take the necessary steps to ensure that all programs provided to the public are accessible. Short-term or temporary solutions can be identified and, if possible, handled by maintenance or added to upcoming capital improvement projects. Areas such as approach and entrances, access to services and restroom access will be evaluated under this initial

approach. As barriers are removed or new ADA compliant facilities open to the public, Ashland City's interim programmatic measures will include evaluating and potentially relocating public services to a compliant facility.

Ashland City will immediately begin to focus on the ADA Transition Plan priorities and seek additional funding opportunities from internal, federal, state and private sources. The annual budgeting process will see increased funding over the 20-year implementation period. Capital improvement projects will be reviewed in order to capture barrier removal opportunities. Ashland City will also initiate a response Log in order to track ADA repairs and removals as required under the Transition Plan.

Ashland City will adapt, by resolution from the governing body, the *Ashland City ADA Facilities Inventory Self-Evaluation and Transition Plan* in order to confirm recommendations presented within.

5.0 ASHLAND CITY GRIEVANCE PROCEDURE

It is the policy of the Town of Ashland City to honor all requests for ADA accommodation when at all possible. The ADA Notice and Grievance Procedure is posted on-line at <https://www.ashlandcitytn.gov/administration/page/grievance-procedure>.

The Grievance Procedure is established to meet the requirements of the Americans with Disabilities Act of 1990 (ADA). It may be used by anyone who wishes to file a complaint alleging discrimination on the basis of disability in the provision of services, activities, programs, or benefits by Ashland City. The City's Personnel Policy governs employment-related complaints of disability discrimination. The complaint should be in writing and contain information about the alleged discrimination such as name, address, phone number of complainant and location, date, and description of the problem. Alternative means of filing complaints will be made available for persons with disabilities upon request.

The complaint should be submitted by the grievant and/or his/her designee, as soon as possible but no later than 60 calendar days after the alleged violation to:

Brian Stinson
Town of Ashland City
101 Court Street
Ashland City, TN 37015
Phone: 615-792-6455

A copy of the current Ashland City Grievance Procedure is included in Appendix C.

Appendix A:

Facilities Inventory Self-Evaluation Requirements

Appendix A

FACILITIES INVENTORY SELF-EVALUATION REQUIREMENTS

CSR staff recorded, on specific facility forms, a multitude of characteristics and measurements needed to assess ADA compliance. Characteristics were recorded such as lengths and slopes using tape measures and smart levels. For other characteristics, such as the type of traffic control at an intersection or sidewalk material, CSR staff simply observed and recorded the condition.

Appendix A has been prepared to aid in the review of the *Facilities Inventory Self-Evaluation Report* and subsequent findings. The requirements and graphic representations presented in Appendix A are based on the information presented in ADA Accessibility Guidelines for Buildings and Facilities (ADAAG), the Proposed Guidelines for Pedestrian Facilities in the Public Right-of-Way (PROWAG) and the Manual on Uniform Traffic Control Devices (MUTCD). Additional illustrations are provided from the New England ADA Center (checklist guides).

Note that the presented Appendix A guidelines are not comprehensive. Rather, CSR has elected to provide the typical or most applicable requirements and schematics for each type of facility evaluated. Please refer to the above guidelines for more detailed requirements or design criteria.

Public Buildings-Interior

Access routes are at least 36 inches wide.



Elevator call buttons no higher than 54 inches.

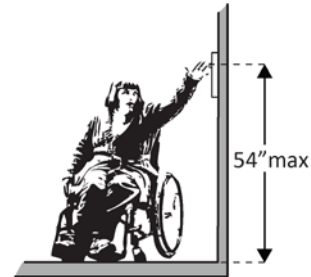

Elevator in-car controls are no less than 15 inches and no greater than 48 inches above floor.

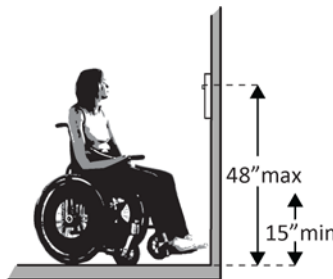

Elevator in-car buttons are designated with raised characters.

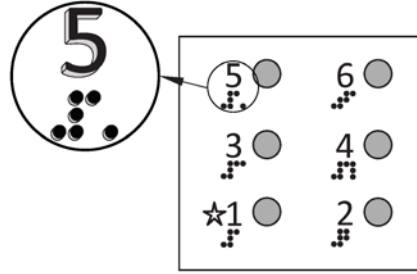

Permanent room signs marked with raised text, braille and mounted on latch side of door.

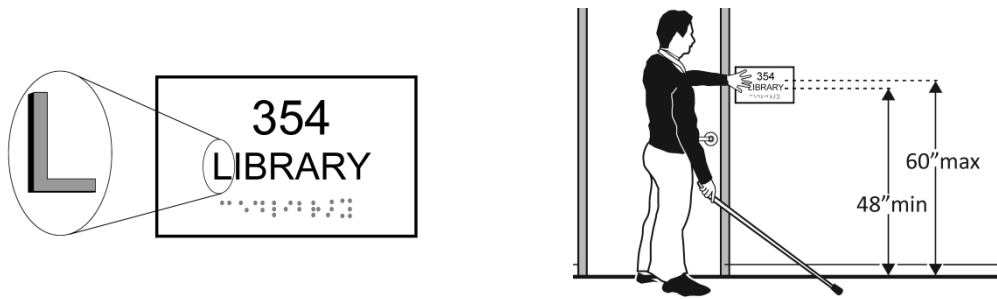

Interior door openings must have at least 32 inches clear at 90 degrees open and have maneuvering clearance.

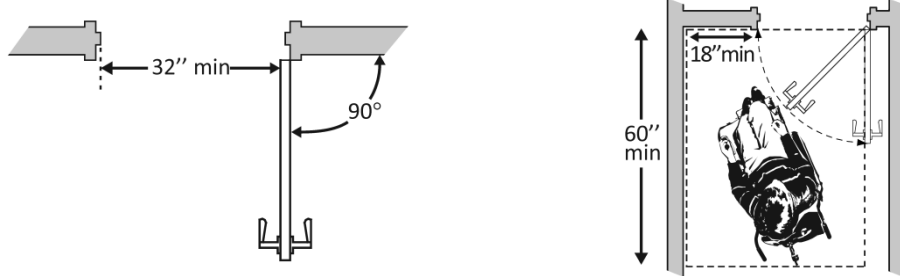

Door to be equipped with hardware that is operable with one hand; opened easily with 5 pounds maximum force.

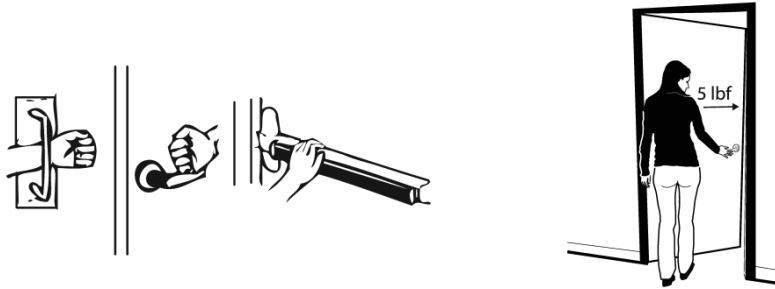

30w x 48l inches of clear floor space and no higher than 48 inches for controls (light switches); operated with one hand.

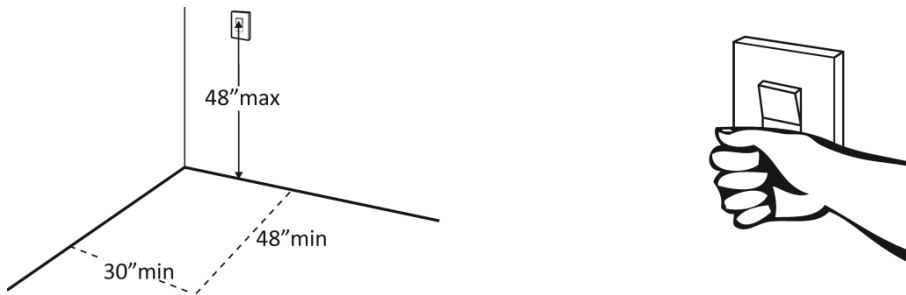

Adequate number of wheelchair spaces; clear line of sight, spacing provided in assembly areas.

# of Seats	Wheelchair Spaces
4 - 25	1
26 - 50	2
51 - 150	4
151 - 300	5



Work surface (table) seating no less than 28 inches and no greater than 34 inches above floor; knee space

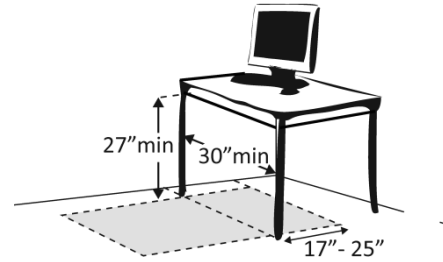
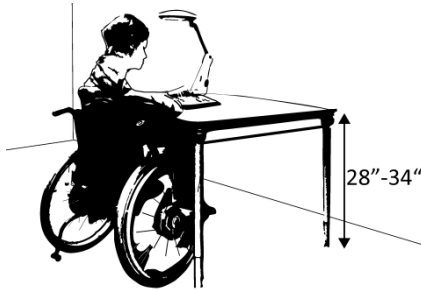

Sales and Service Counters no higher than 36 inches above floor and at least 36 inches long. Clear floor space at least 30 inches wide by at least 48 inches long for approach.

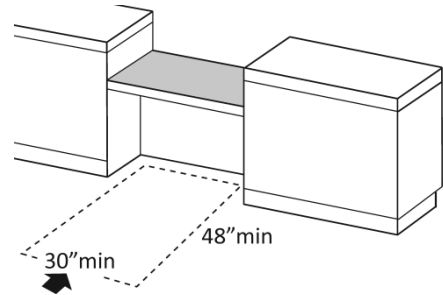
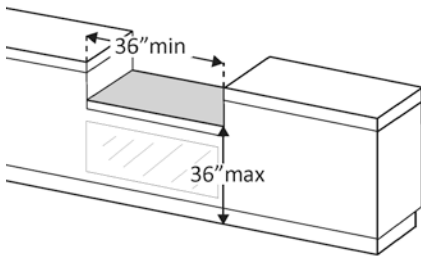

Signs at inaccessible toilet rooms should give direction to nearest compliant toilet room which should have International Symbol of Accessibility.



A clear path to at least each type of fixture (lavatory, hand dryer, etc.) at least 36 inches wide. Clear floor space for wheelchair to turn around at least 60 inches in diameter or 60 inches square.

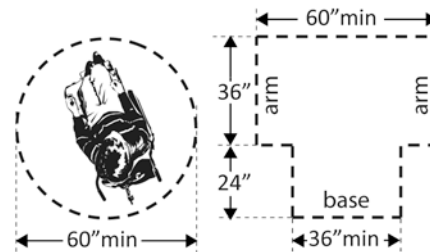

One lavatory should have a clear floor space for a forward approach of at least 30L x 49W inches with no less than 17 inches and no greater than 25 inches if clear floor space under the lavatory for faucet reach.

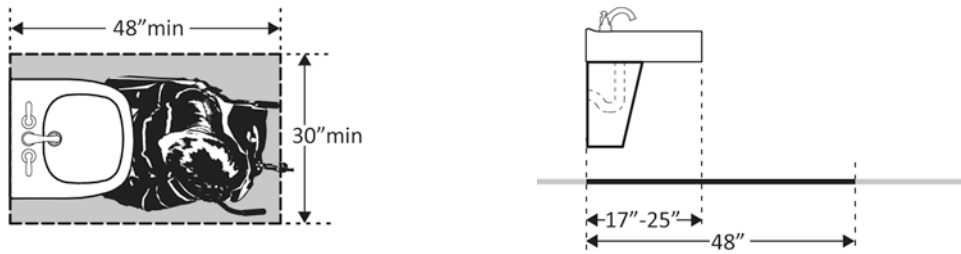

Front of lavatory or counter no more than 34 inches above floor; at least 27 inches knee space clearance from the floor to bottom of lavatory.



Soap dispensers, hand dryers and towels dispenser should be with range of the following reaches.

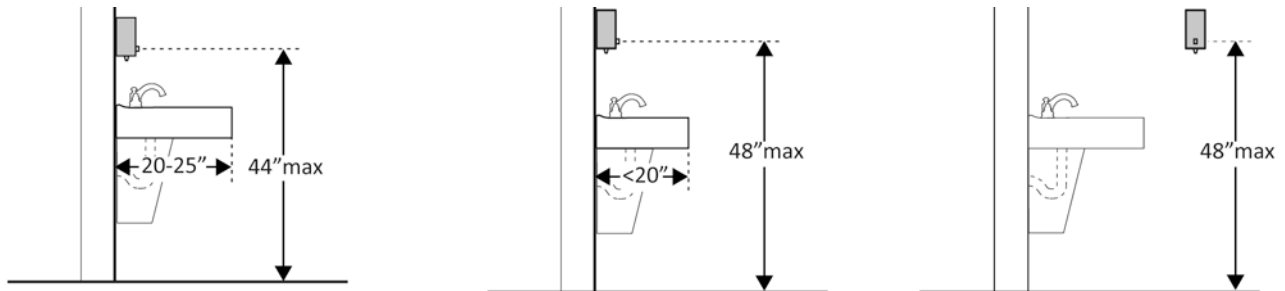

Clearance provided around the toilet measuring at least 60 inches from the side wall and at least 56 inches from the rear wall? The centerline of the toilet no less than 16 inches and no greater than 18 inches from the side wall or partition. The height of the toilet no less than 17 inches and no greater than 19 inches above the floor

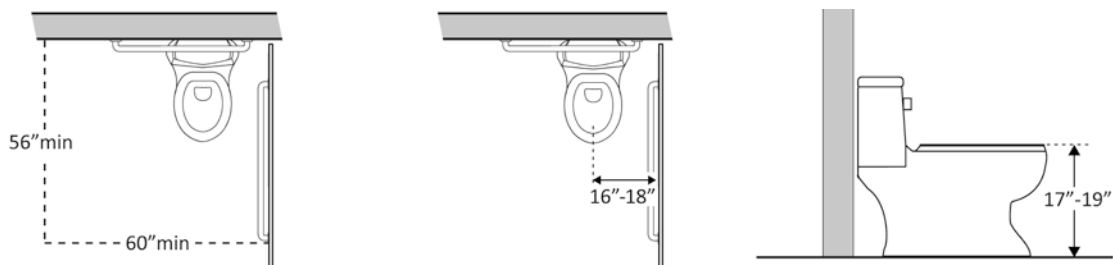

Grab bar at least 42 inches long on side wall and mounted no less than 33 inches and no greater than 36 inches above the floor to top of gripping surface.

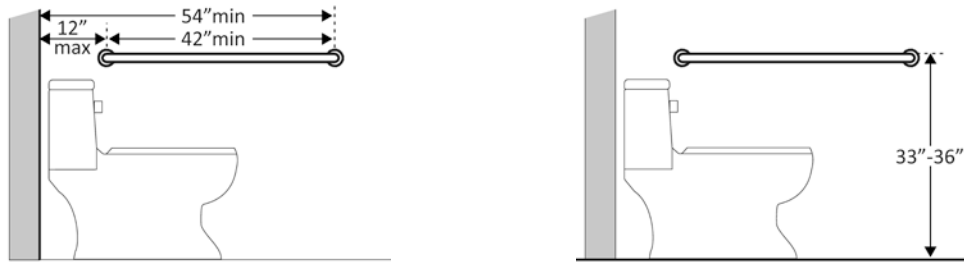

Hand operated flush control located no higher than 48 inches above floor; easily operated with one hand and located on open side of toilet.

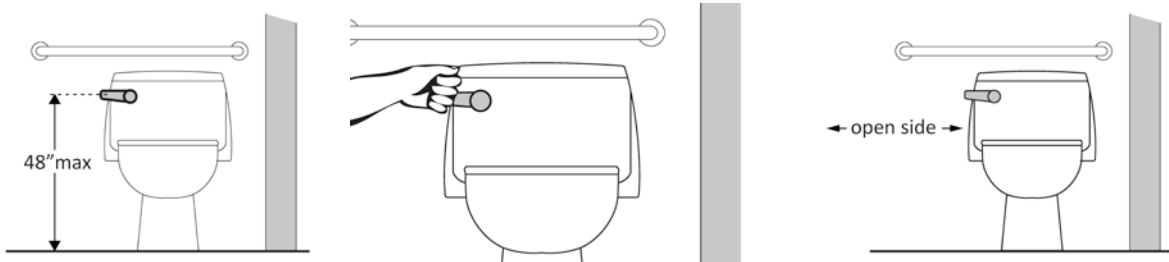

The toilet paper dispenser located no less than 7 inches and no greater than 9 inches from the front of the toilet to the centerline of the dispenser. Dispenser outlet located no less than 15 inches and no greater than 48 inches above the floor.



Clearance of stall door opening width at least 32 inches and self-closing.



At least one drinking fountain must have a clear approach and floor space at least 30 inches wide x 48 inches long; spout outlet no higher than 36 inches above floor.

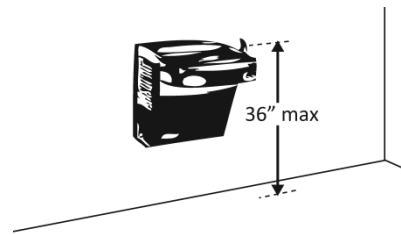
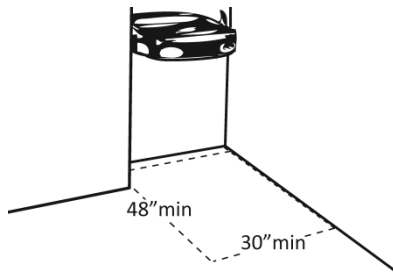

Fountain should be mounted according to the following dimensions.

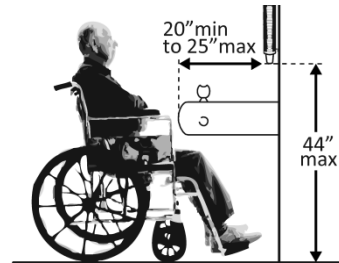
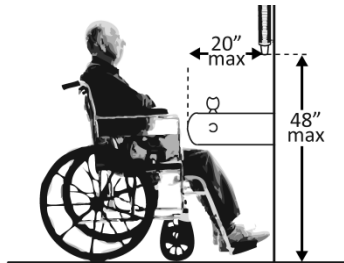

Public Facilities-Recreational

Accessible route (36" minimum) to each type of sport activity; each side of court sports; each side of team or player seating. At least one wheelchair space at team or player seating.

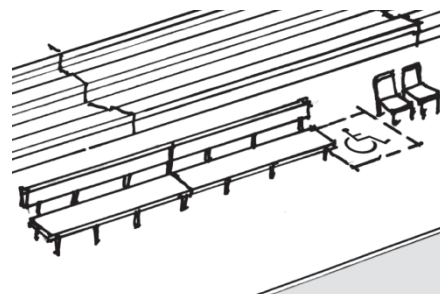

At least one bench should have the following seating dimensions.

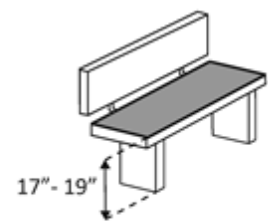
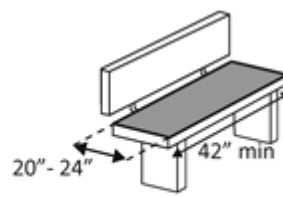
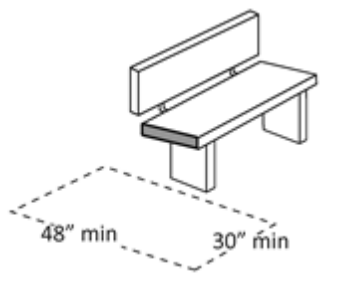

Public Buildings & Facilities-Approach, Parking and Entrance

An adequate number of accessible spaces should be provided. For every 6 or fraction of 6 accessible spaces, one should be van accessible. Accessible spaces should be at least 8 feet wide with access aisle of at least 5 feet wide.

Total Spaces	Accessible Spaces
1 - 25	1
26 - 50	2
51 - 75	3
76 - 100	4

100+ see 2010 Standards 208.2

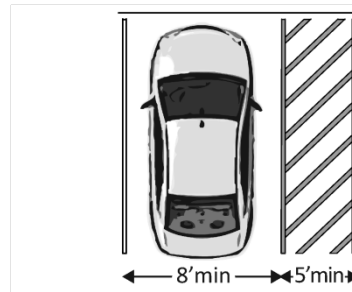

Access aisle should be marked to discourage parking and adjoin an accessible route closest to accessible entrance.

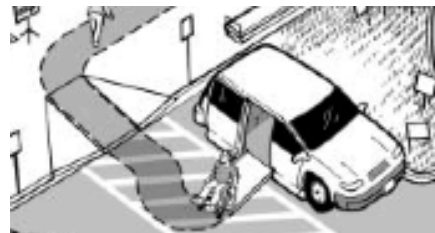
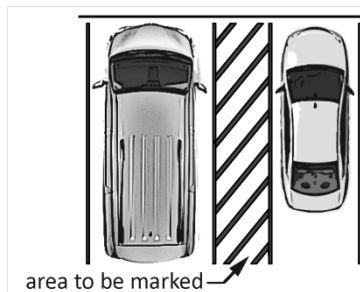

Accessible spaces identified with a sign that includes the International Symbol of Accessibility with bottom of sign at least 60 inches above the ground.

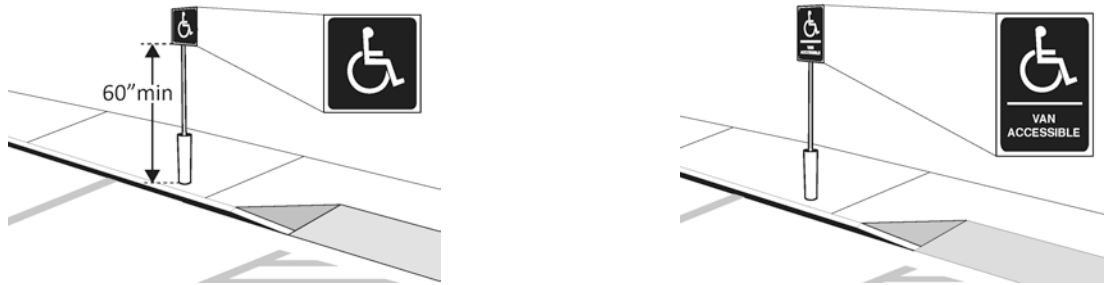

Approach ramps should be at least 36 inches wide. If rise is higher than 6 inches, handrails should be on both sides.

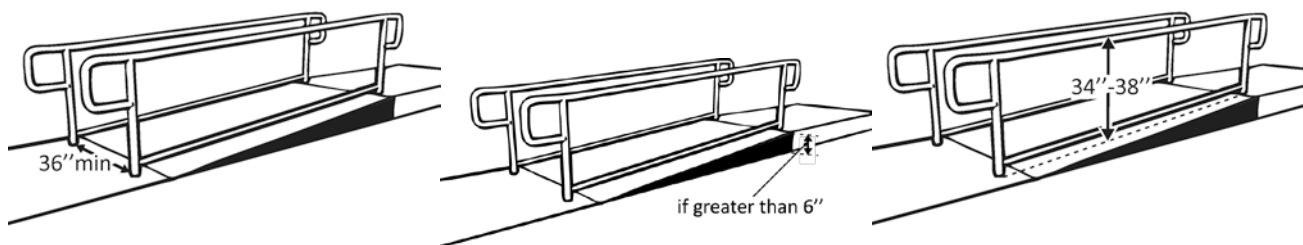

Handrail gripping surfaces should be the following dimensions and extend at least 12 inches beyond the top and bottom of ramp.

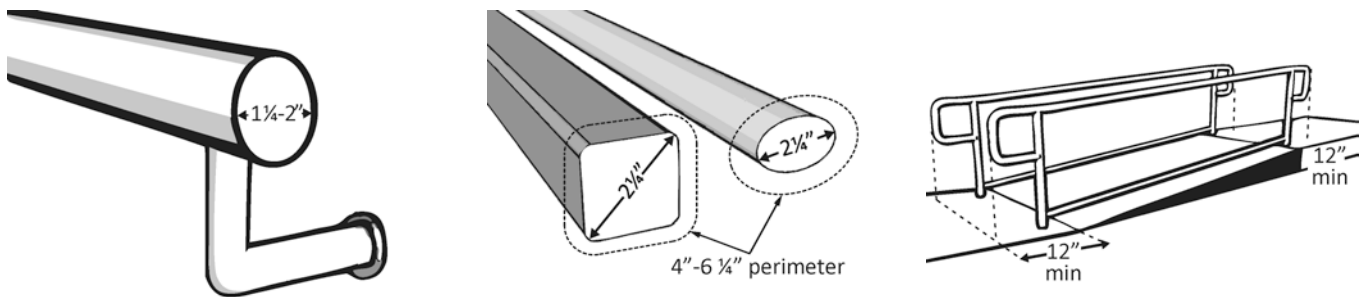

If the main entrance is not accessible, there should be an alternative accessible entrance. Inaccessible entrances should have signs indicated direction to nearest accessible entrance.

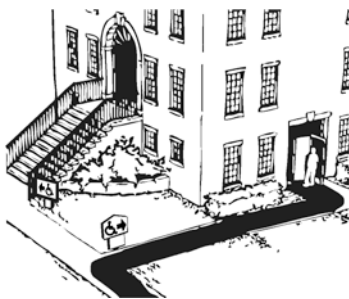

Pedestrian Access Route

- Width: 4' minimum, exclusive of curb; 5' preferred, if less than 5' passing spaces must be provided every 200'.
- Running Slope (Grade): shall not exceed >5% unless grade of adjacent street is over 5%.
- Cross Slope: shall be 2% maximum.
- Surface Condition: shall be firm and stable, slip resistant. Vertical discontinuities (changes in level) shall be ½" maximum; with those between ¼" and ½" being beveled. Horizontal openings, such as grates and joints may not exceed ½".
- Obstructions and Protrusions: disallows passable sidewalk space of 4', leading edges between 27" and 80" above the finished surface and protrude more than 4" horizontally into the path. (utility poles, hydrants, mail boxes, vegetation, signs, furniture)

Route should be at least 36 inches wide exclusive of width of curb or can narrow to 32 inches minimum for a maximum length of 24 inches.

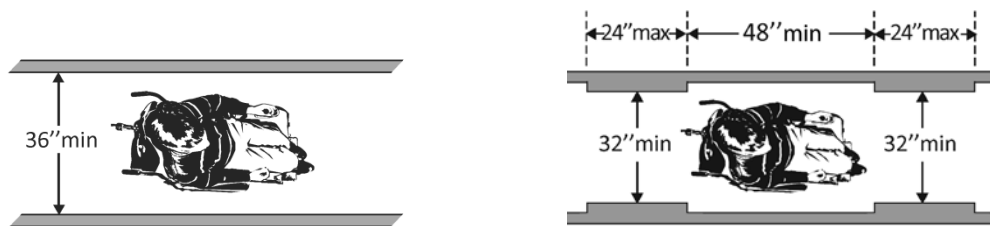

If route is greater than 200 feet in length and less than 60 inches wide, there should be a passing space no less than 60 x 60 inches.

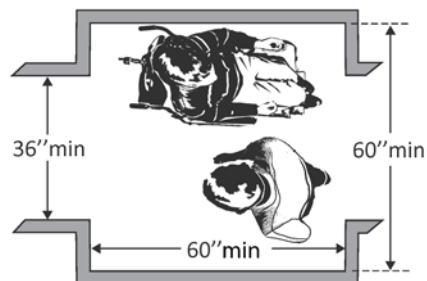

Cross slope no steeper than 1:48 (2%)

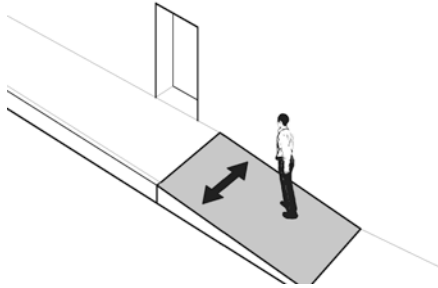

Running Slope no steeper than 1:12 (5%)

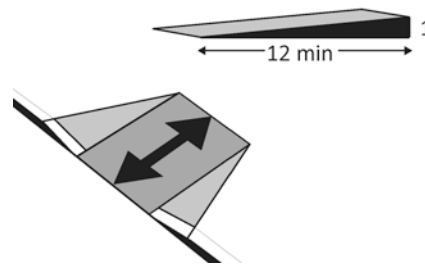

Grates or horizontal openings along the route are no larger than 1/2 inch.

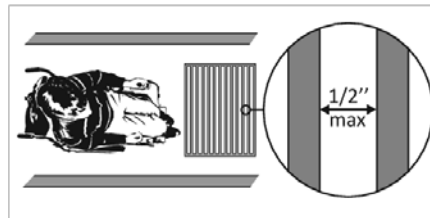

Vertical discontinuities (changes in level) shall be 1/2" maximum; with those between 1/4" and 1/2" being beveled.

6.4 max
1/4



6.4-13
1/4-1/2



Obstructions and Protrusions disallows passable sidewalk space of 4', leading edges between 27" and 80" above the finished surface and protrude more than 4" horizontally into the path (utility poles, hydrants, mail boxes, vegetation, signs, furniture).

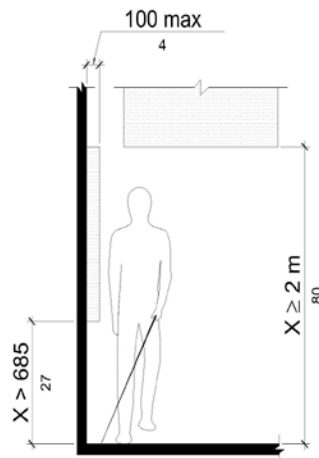

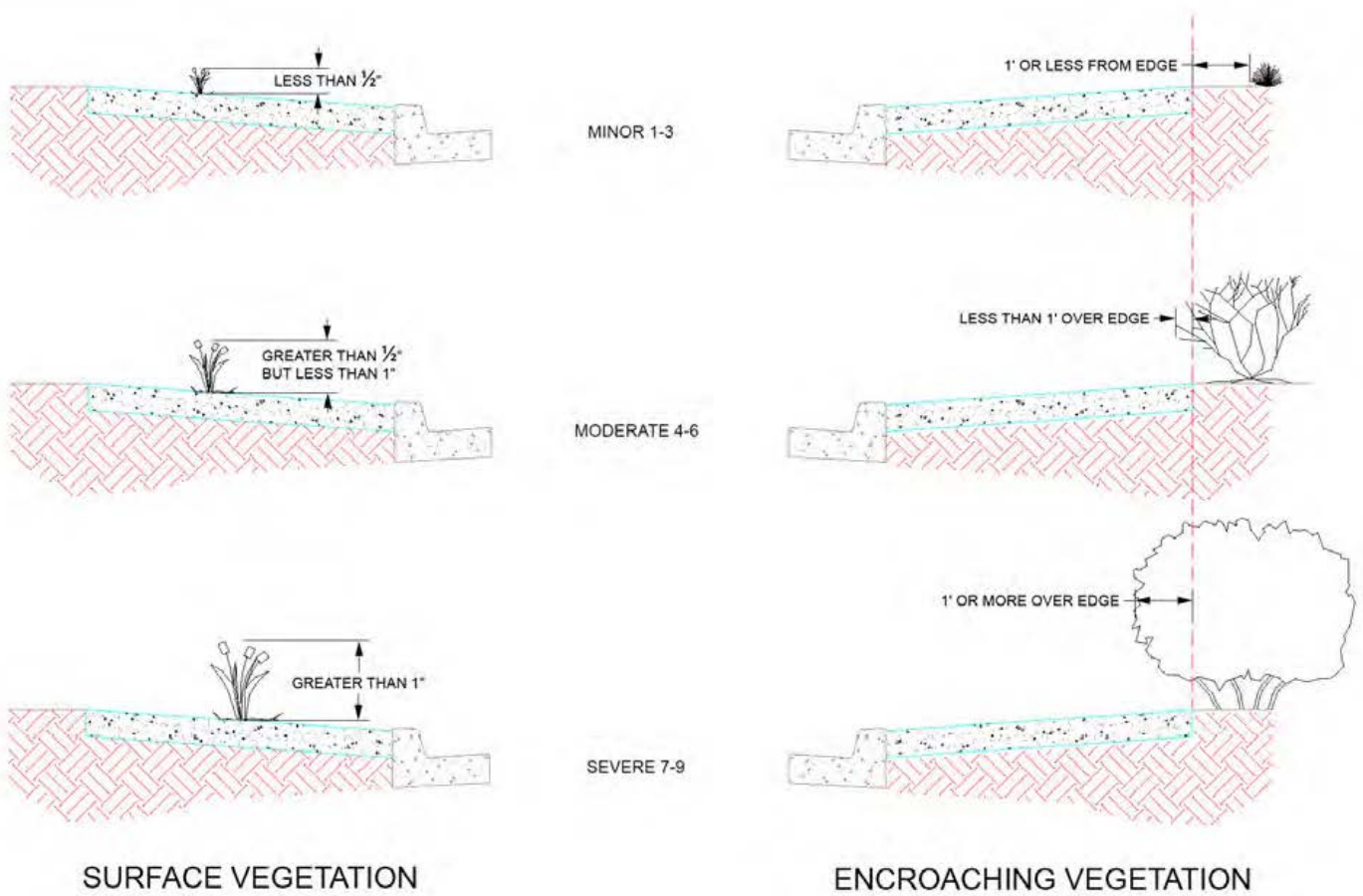
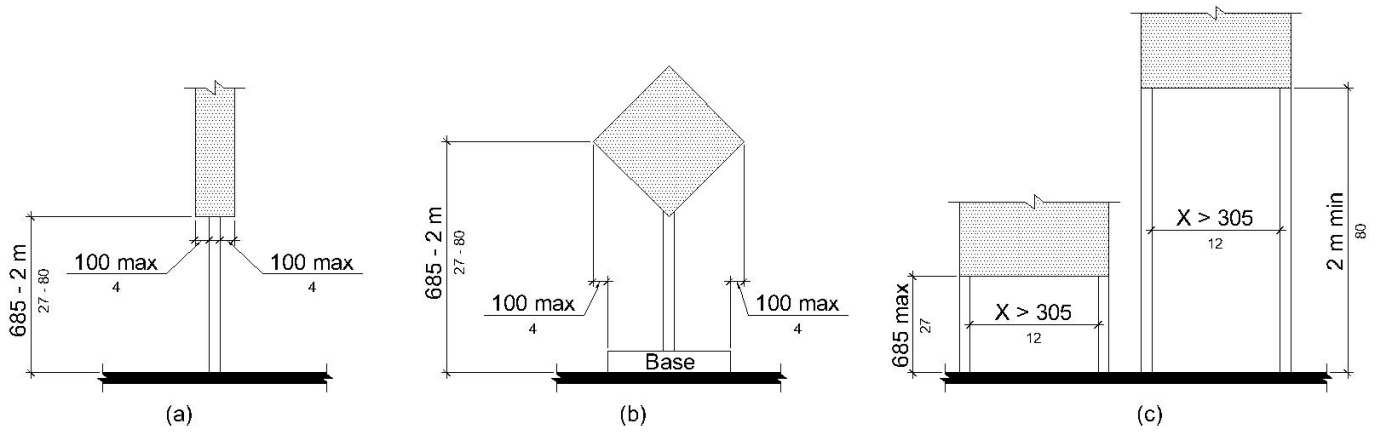

The following dimensions apply to the size, placement and extension of detectable warnings.

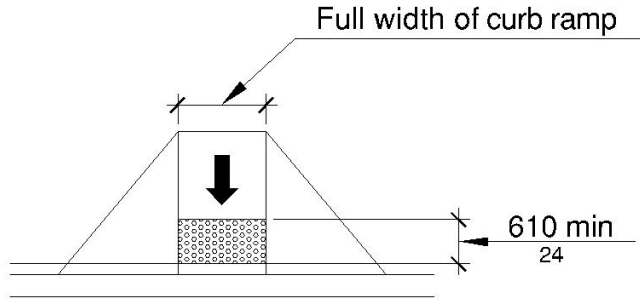

(a) perpendicular

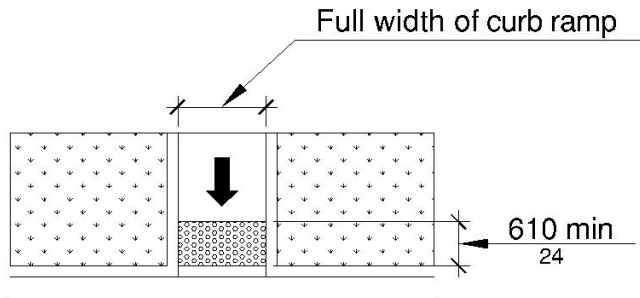

(b) returned curb

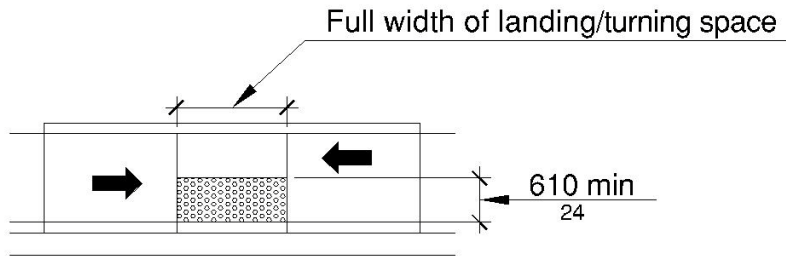

(c) parallel

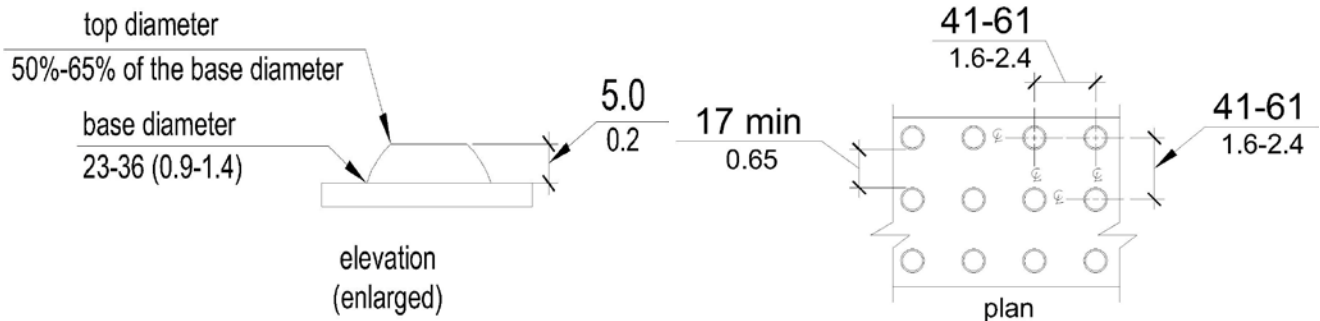

Perpendicular Curb Ramps-Detectable Warning Placement

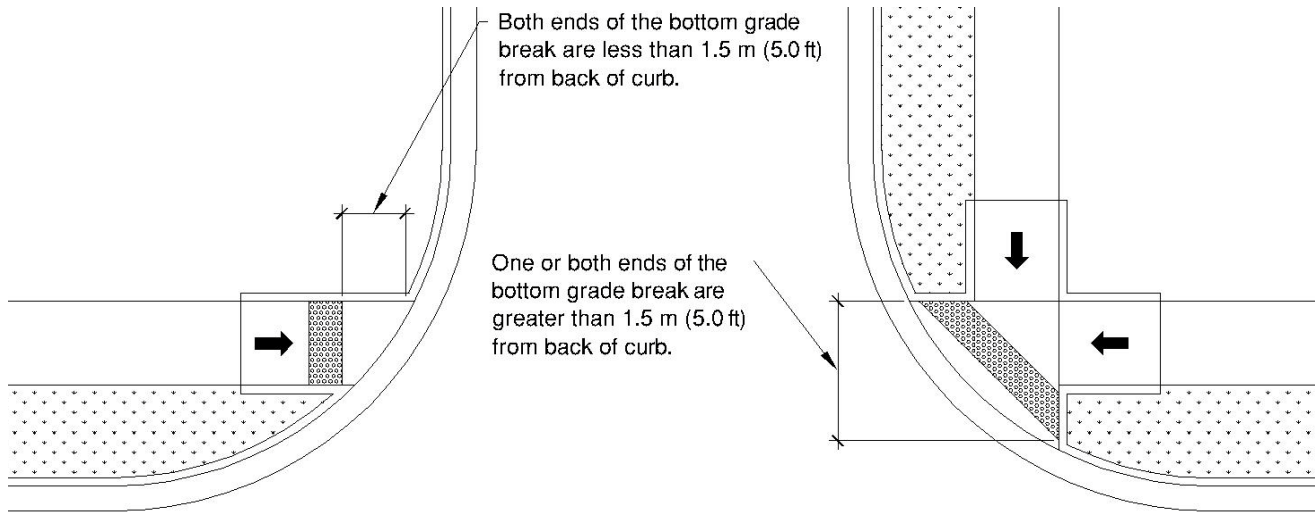

Parallel Curb Ramps-Detectable Warning Placement

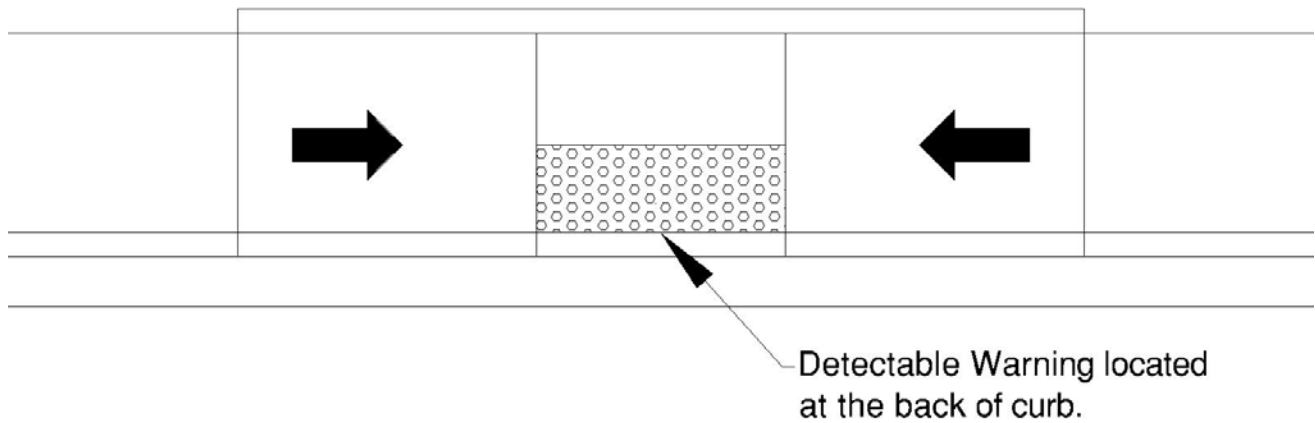

Blended Transition Ramps-Detectable Warning Placement

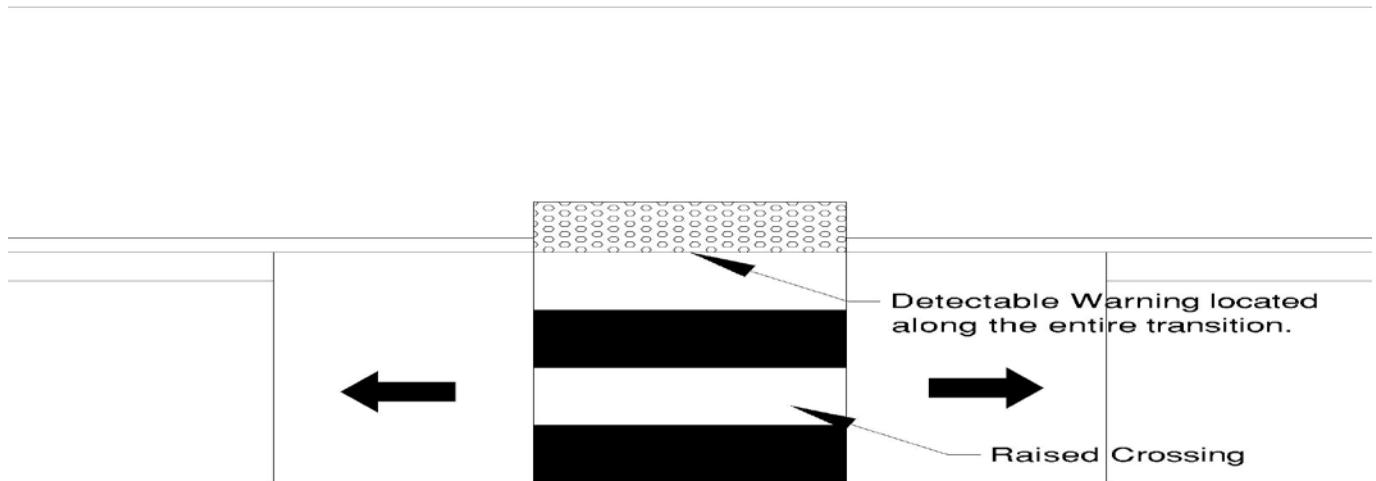

Pedestrian Access Route-Curb Ramps

- Curb Ramp Width: shall be 4' minimum.
- Curb Ramp Running Slope: shall be no steeper than 8.3%.
- Curb Ramp Cross Slope: shall be 2% maximum.
- Curb Ramp Landings/Turning Spaces: shall be minimum of 4' by 4' or 4' by 5' if constrained.
- Ramp Flares: shall not exceed 10% maximum.
- Ramp Grade Breaks and Clear Space: breaks should be perpendicular to direction of ramp and flush. Clear space beyond the bottom grade break should be 4' by 4' minimum.
- Ramp Obstructions, Protrusions, Vertical Discontinuities, Horizontal Openings: shall maintain 4' minimum width and are subject to sidewalk guidelines for same.

Typical/General requirements for curb ramps.

Perpendicular Curb Ramps

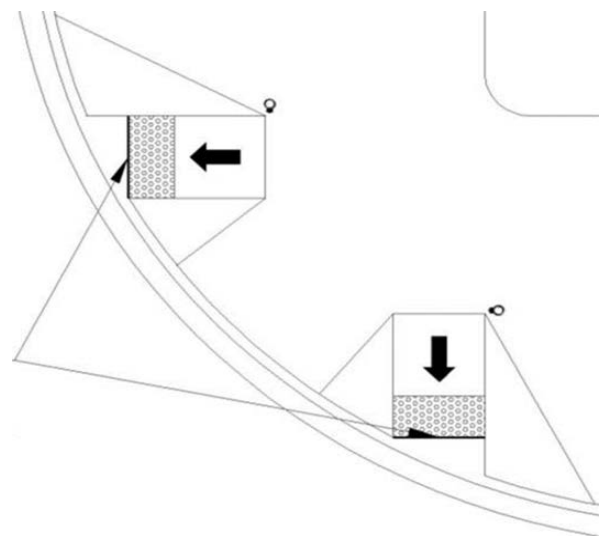

Note: The running slope of the curb ramp shall be 5 percent minimum and 8.3 percent maximum but shall not require the ramp length to exceed 4.5 m (15.0 ft). The running slope of the turning space shall be 2 percent maximum

Perpendicular Curb Ramps-Turning Space

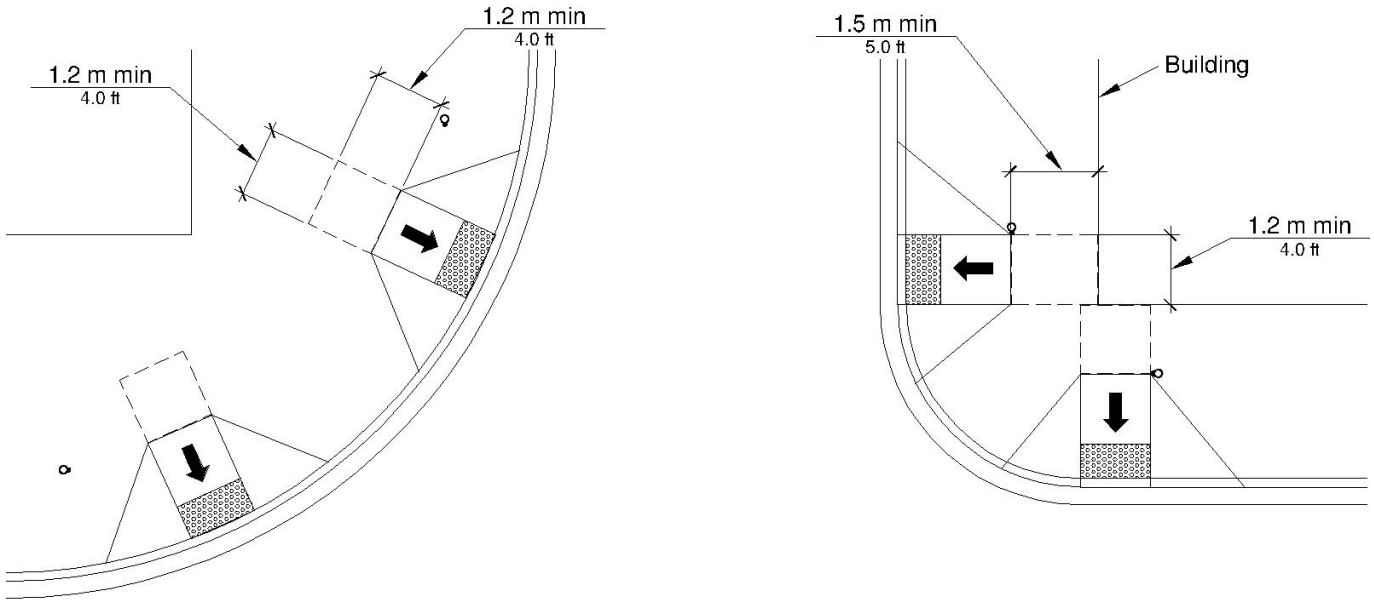

Parallel Curb Ramps

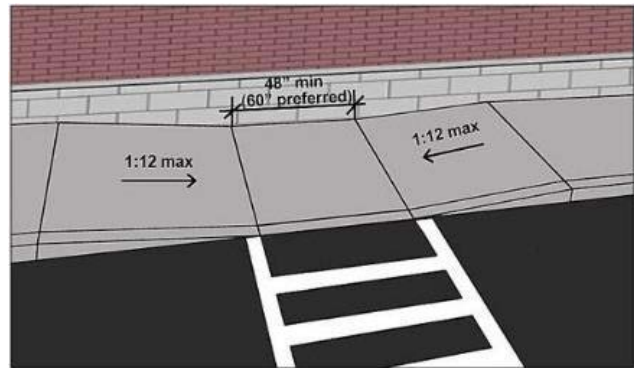

Note: The running slope of the curb ramp shall be 5 percent minimum and 8.3 percent maximum but shall not require the ramp length to exceed 4.5 m (15.0 ft). The running slope of the turning space shall be 2 percent maximum.

Parallel Curb Ramps-Turning Space

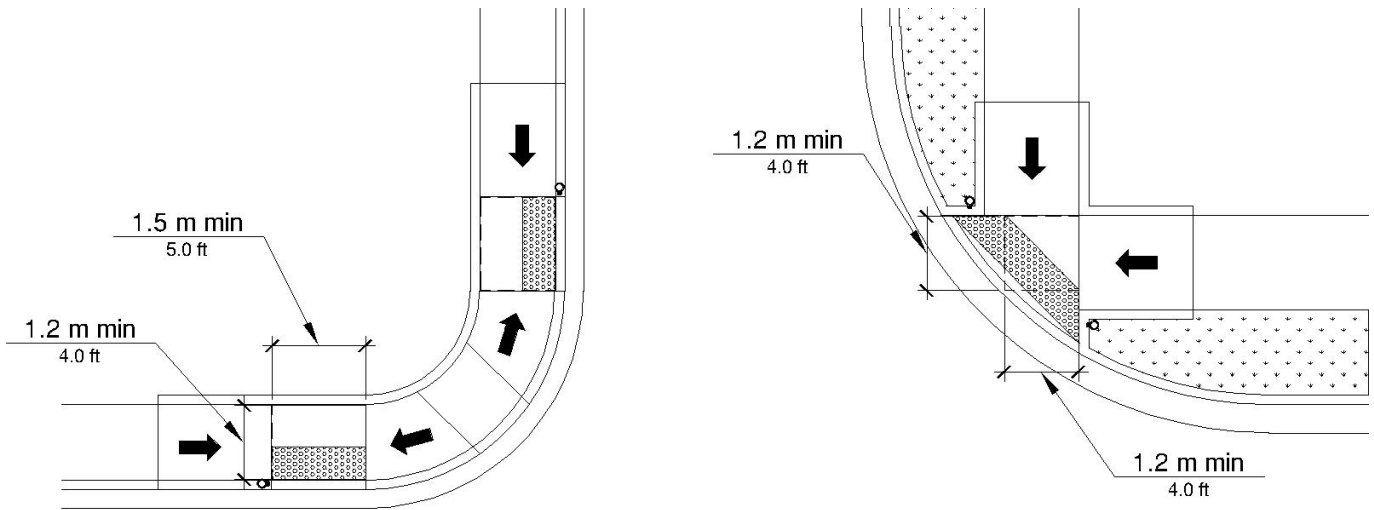

Combination Curb Ramps

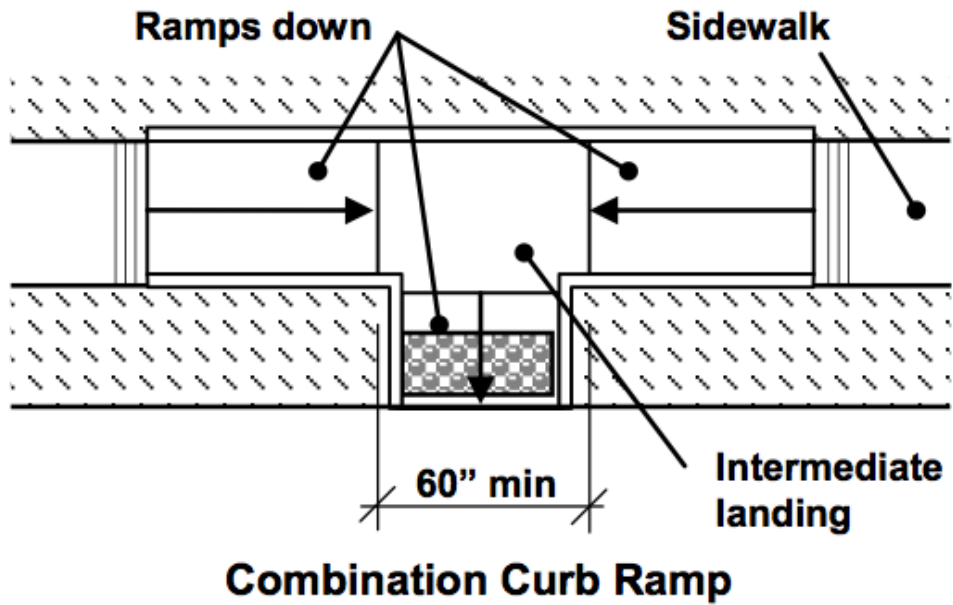

Blended Curb Ramps

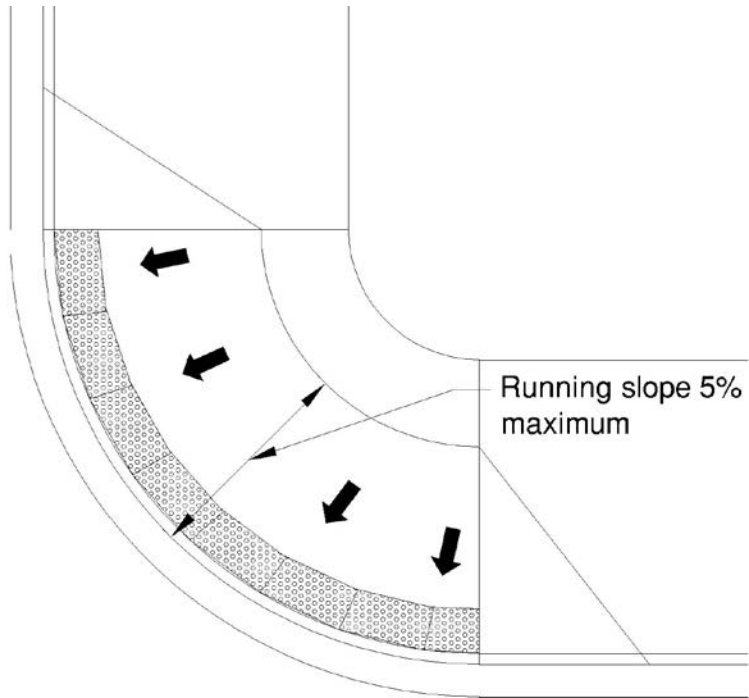

General Ramp Width

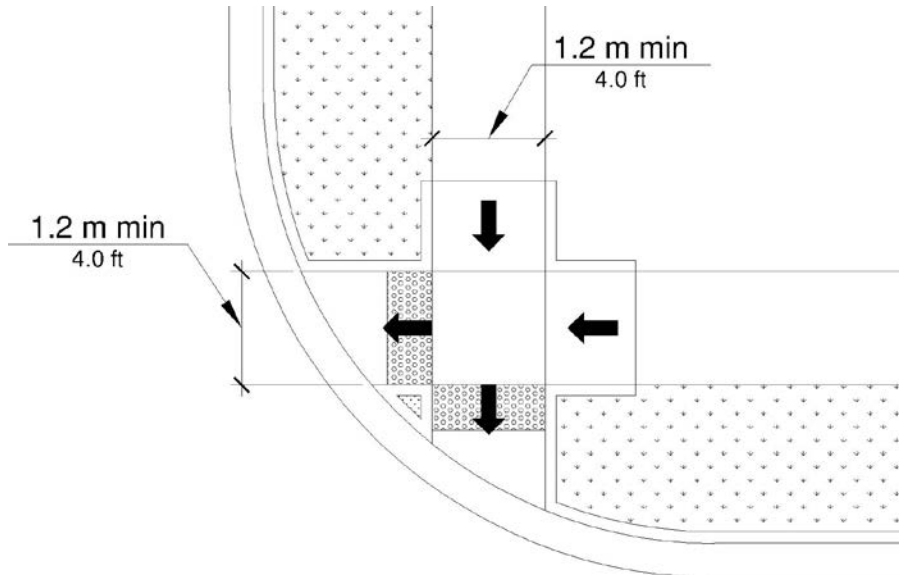

General Ramp Running and Cross Slopes

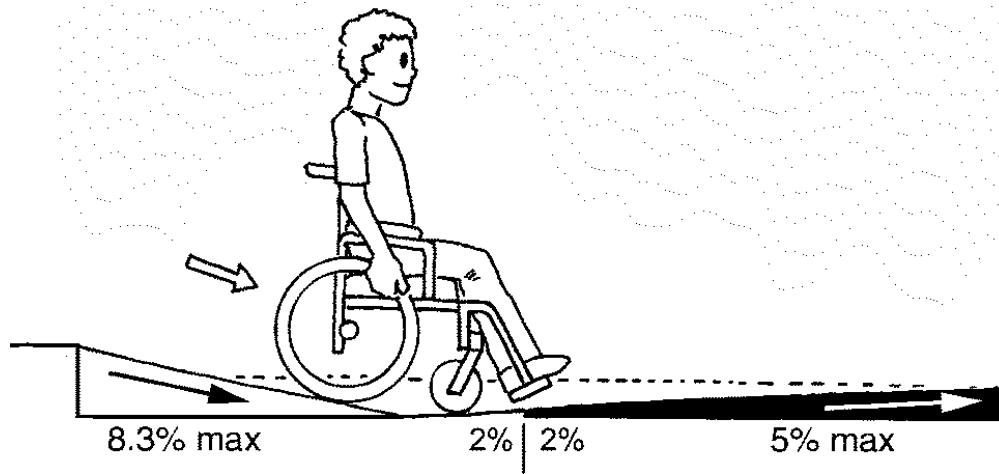

General Ramp Grade Breaks

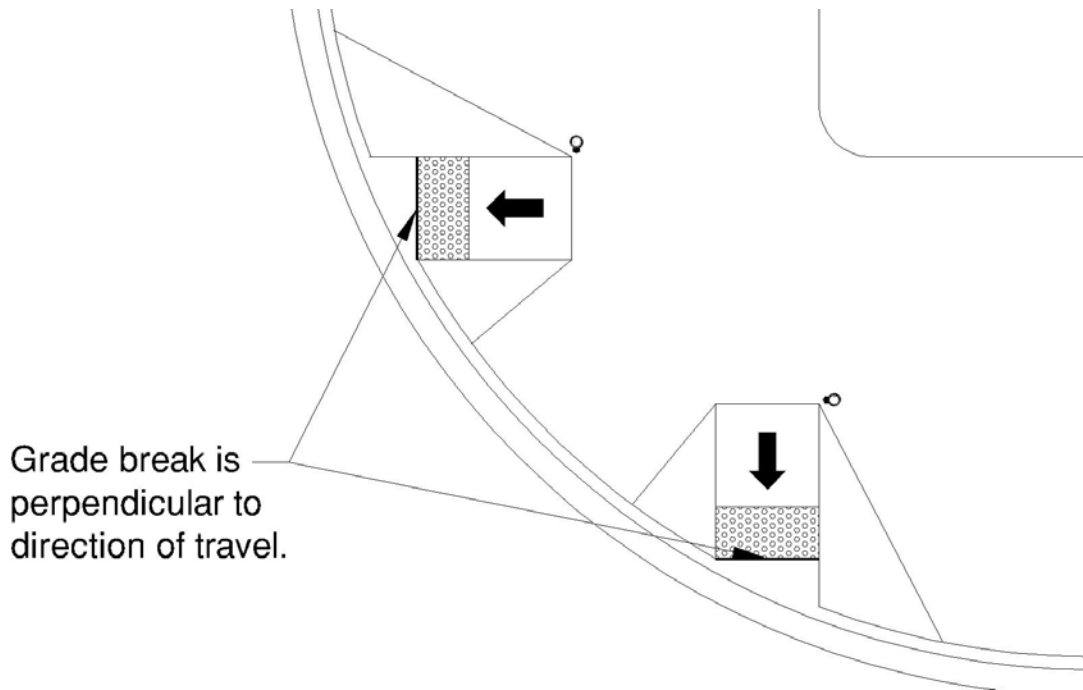

General Ramp Clear Space

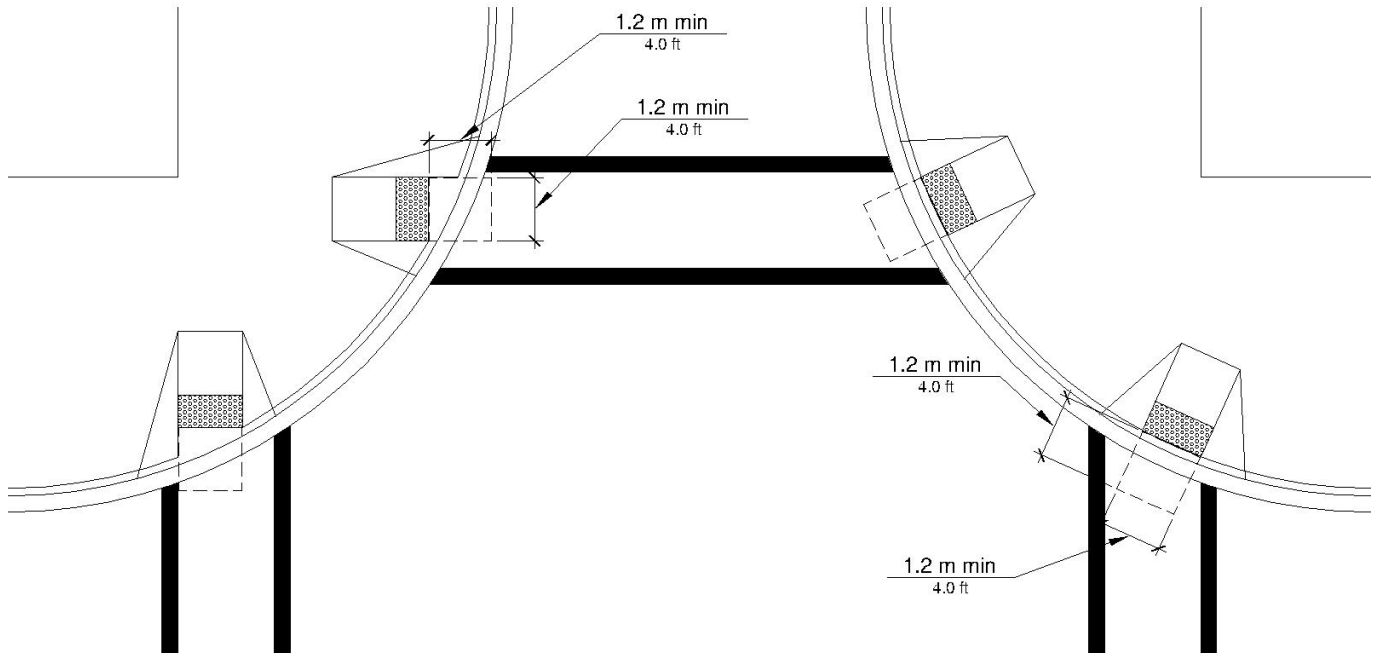

Accessible Pedestrian Signals

Recommended pushbutton location for accessible pedestrian signals

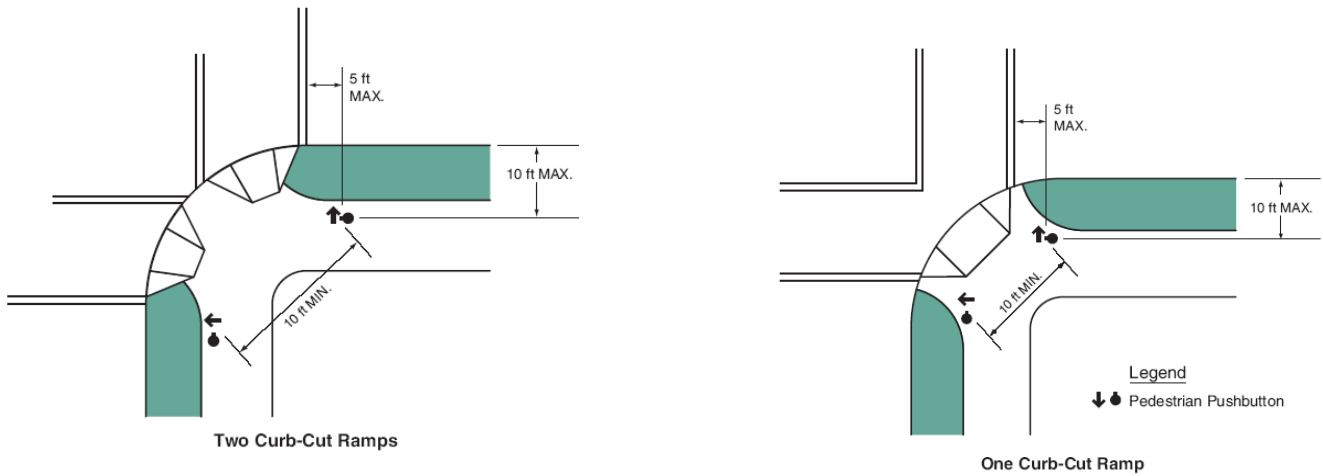

Example of Accessible Pedestrian Pushbuttons



Example of pushbuttons on shared pole



Example of required signage, tactile arrow, and audible functions



Appendix B:

Detailed Self-Evaluation Supporting Documentation

Ashland City-ADA Sidewalk Inventory					
Street Name	Sidewalk Side	Start/End/Location	Length/Location	Deficiency Type	Deficiency Notes/Observations
Vantage Pointe Rd.	North	Entrance Drive off HWY 12	63' length of path		
Vantage Pointe Rd.	North	Across from Entrance Dr. end NE to SE	282' length of path		
Little Marrowbone Rd	East	Start of Sidewalk - Near Park		Discontinuity	No transition to grassed area
Little Marrowbone Rd	East	Driveway 1 from HWY 12-Sidewalk Ramp	Driveway	Ramp Slope	Running slope (both sides) >8.3%
Little Marrowbone Rd	East	Driveway 1 from HWY 12-Sidewalk Ramp	Driveway	Cross Slope	Cross slope (both sides) >2.0%
Little Marrowbone Rd	East	Driveway 3 from HWY 12-Both Sides	Driveway	Discontinuity	>1/4" both sides transition concrete to asphalt
Little Marrowbone Rd	East	2-feet NE from Driveway 3		Obstruction	Utility Pole within 5.0 foot sidewalk route
Little Marrowbone Rd	East	20.5 feet NE from Driveway 3		Discontinuity	>1/4"
Little Marrowbone Rd	East	End of Sidewalk - Past Driveway 3		Discontinuity	No transition to grassed area
Cumberland St.	North	Side of McCoy Building		Slope/Grade	Running slopes >5.0%
Cumberland St.	North	On-Street Handicap Parking	Side of McCoy Bldg.	Handicap Access	Aisle/ramp not provided
Cumberland St.	South	69 feet SW of Main Street		Obstruction	Water Valve and Concrete Steps
Cumberland St.	South	Fitness Center including Alley Crossing to Ramp	105' length of path	Discontinuity	>1/4" entire length of section, cracks, transitions and slopes
Cumberland St.	South	On-Street Handicap Parking	Main & Cumberland	Handicap Access	Aisle/ramp not provided
N Vine	North	Rhea Street and 10 Feet N of Rhea Street		Discontinuity/Obstruction	>1/4", two > 4.0" sidewalk step-ups
N Vine	North	Church of Christ HC Ramp to Vine Street Sidewalk		Detectable Surface	No detectable warning surface present on Ramp to Street
Rhea Alley	North	Back of Heritage Bank		Discontinuity/Obstruction	>1/4", two > 10.0' sidewalk step-ups
Frey Street (SR-49)	South	Segment 1: Front of Childrens Services Department		Discontinuity	>1/4" at start of Sidewalk Ramp; No Guard at end-step down to grass
Frey Street (SR-49)	South	Segment 2: Main Street to 114 Frey Street	108 Frey Street	Discontinuity	>1/4", Crack (2)
Frey Street (SR-49)	South	Segment 2: Main Street to 114 Frey Street	106 Frey Street	Discontinuity	>1/4", Crack
Frey Street (SR-49)	South	Segment 2: Main Street to 114 Frey Street	Start of Sidewalk	Discontinuity	>1/4", Transition to Asphalt
Frey Street (SR-49)	North	Segment 3: Main Street to Court Street	207' E of Main	Slope/Grade	Running slopes >5.0%
Frey Street (SR-49)	North	Segment 3: Main Street to Court Street	10' W of Court St	Slope/Grade	Running slope > 5.0%
Frey Street (SR-49)	North	Segment 3: Main Street to Court Street	Side of County Bldg.	Obstructions	Gutter Downspouts & PVC Cleanout Cap
Ruth Dr	North	100 Feet from Sidewalk Start NE of Main St to		Obstruction	Utility Pole in Sidewalk Edge
Ruth Dr	North to West	Sidewalk Curve from NE to North		Discontinuity	Cracks throughout sidewalk curve
Ruth Dr	North to West	All Ramps and Driveways on Ruth Street	Ramps and Driveways	Ramp Slope	Running slope (both sides) >8.3%
Ruth Dr	North to West	All Ramps and Driveways on Ruth Street	Ramps and Driveways	Cross Slope	Cross slope (both sides) >2.0%
Sycamore St	North	N Main Past Lloyd Harris Bonds	95' length of path		
Sycamore St	South	N Main to Parking Lot Driveway	142' length of path	Width	Entire length < 4.0 feet
Sycamore St	South	N Main Ramp to Sidewalk		Ramp Discontinuity	Discontinuity: cracked
Court St	West	Frey Street (49) to Sycamore Steet	267' length of path	Width	Varying widths with over 60 feet < 4.0 feet,
Court St	West	On-Street Handicap Parking		Handicap Access	Aisle/ramp not provided
Stratton Blvd	North	S Main to 1st Driveway on Left	73' length of path	Width	Entire length < 4.0 feet
Stratton Blvd	North	Last 37 feet to Driveway	37' length of path	Discontinuity	>1/4" entire length of section, cracks, gravel
Stratton Blvd	South	S Main to 1st Driveway on Right	140' length of path		
Helen St	South	S Main to Duke Street	248' length of path	Width	Entire length < 4.0 feet, overgrown, disrepaired areas
Helen St	South	45 feet NE of Fire Hydrant		Discontinuity	>1/4"
Helen St	South	Both Driveway Sidewalk Ramps	Driveways (2)	Ramp Slope	Running slopes >8.3%
Helen St	South	Both Driveway Sidewalk Ramps	Driveways (2)	Cross Slope	Cross slope >2.0%, <4.0 width
Duke St	West	106 Duke Street Parking Entrance to Helen Street	124' length of path	Width	Entire length < 4.0 feet, overgrown, disrepaired areas
Duke St	West	106 Duke Street Parking Entrance - Sidewalk Ramp	Driveway	Ramp Slope	Running slope >8.3%
Duke St	West	106 Duke Street Parking Entrance - Sidewalk Ramp	Driveway	Cross Slope	Cross slope >2.0%, <4.0 width
Elizabeth St	West	S Main to Elementary School Drive	338' length of path	Discontinuity	Entire length of section, cracks, gravel, broken
Elizabeth St	West	Elementary School Drive to Lowe Street		Width	Handicap 5 x 5 passing spaces not provided every 200' (SW width <5.0')
Elizabeth St	West	149 Feet of Fire Hyrant		Discontinuity	>1/4"

Ashland City-ADA Sidewalk Inventory					
Street Name	Sidewalk Side	Start/End/Location	Length/Location	Deficiency Type	Deficiency Notes/Observations
Elizabeth St	East	North of Lowe Street-Sidewalk Section and Ramp-Funeral Home	65' length of path	Discontinuity	Entire section needs replaced-cracks
Hwy 12/ Main St	East	Forrest Street to Helen Street	684' length of path	Cross Slope	>2% entire segment length
Hwy 12/ Main St	East	Forrest Street to Helen Street	684' length of path	Width:	Handicap 5 x 5 passing spaces not provided every 200' (SW width <5.0')
Hwy 12/ Main St	East	Forrest Street to Helen Street	Culvert Crossing 16' N of Forrest	Width	Reduces to 3' 3" for 8-foot length
Hwy 12/ Main St	East	Forrest Street to Helen Street	End of Culvert Crossing	Discontinuity	>1/4"
Hwy 12/ Main St	East	Forrest Street to Helen Street	64' N of Culvert Crossing	Discontinuity	>1/4"
Hwy 12/ Main St	East	Forrest Street to Helen Street	Between Sonic Drives	Discontinuity	>1/4" , Cracked and broken above water line
Hwy 12/ Main St	East	Forrest Street to Helen Street	End of Sidewalk at Helen Street	Discontinuity	>1/4" , Cracked
Hwy 12/ Main St	East	Forrest Street to Helen Street	S Driveway to Rite Aid	Ramp	No rightside ramp, cross slope >2.0%
Hwy 12/ Main St	East	Forrest Street to Helen Street	N Driveway to Rite Aid	Ramp	No leftside ramp, cross slope >2.0%
Hwy 12/ Main St	East	Forrest Street to Helen Street	S Driveway to Sonic	Ramps	Both sides are less than 4.0' , cross slopes >2.0%
Hwy 12/ Main St	East	Forrest Street to Helen Street	N Driveway to Sonic	Ramp	Right ramp cross slope >2.0%
Hwy 12/ Main St	East	525 S. Main to Turner Street	159' length of path		
Hwy 12/ Main St	East	Turner Street to Advanced Auto Driveway	4' N of Turner Street	Discontinuity	>1/4" , Cracked
Hwy 12/ Main St	East	Turner Street to Advanced Auto Driveway	40' N of Turner Street, storm grate	Discontinuity	>1/4" , Cracked
Hwy 12/ Main St	East	Boyd Street to 395 S. Main	Start of Segment at Boyd Street	Discontinuity	No transition to grassed area /Boyd Street
Hwy 12/ Main St	East	395 S. Main to Stratton Street	30' S of 315 Main Street	Discontinuity	>1/4"
Hwy 12/ Main St	East	395 S. Main to Stratton Street	Ramps at Walgreens Driveway	Ramps	Grade breaks not perpendicular to ramp direction
Hwy 12/ Main St	East	Stratton Street to King Automotive Trucks	292' length of path	Width	Entire length < 4.0 feet,
Hwy 12/ Main St	East	Stratton Street to King Automotive Trucks	Ramp to King Auto	Discontinuity	>1/4" , Width
Hwy 12/ Main St	East	107 S. Main to Frey Street (Highway 49)	178' length of path		
Hwy 12/ Main St	East	Frey Street (49) to Sycamore Steet Fronting Court House Complex		Obstructions	Three Signal Poles; Three Lamp Posts reducing Width and passing
Hwy 12/ Main St	East	Frey Street (49) to Sycamore Steet Fronting Court House Complex	Cumberland St. Crossings	Obstructions	Ramps to Cumberland St Crossings blocked
Hwy 12/ Main St	East	Syamore Street to Shell Driveway	157' length of path		
Hwy 12/ Main St	West	Lowe Street to N. of Pinnacle Bank Drive	207' length of path		
Hwy 12/ Main St	West	Cheatham Lake Condos to Elizabeth Street	Hardee's to Gorilla Muffler-470 ft.	Width	Handicap 5 x 5 passing spaces not provided every 200' (SW width <5.0')
Hwy 12/ Main St	West	Cheatham Lake Condos to Elizabeth Street	30' N. of Boyds Funeral Home	Discontinuity	>1/4"
Hwy 12/ Main St	West	Cheatham Lake Condos to Elizabeth Street	Front of Hardees	Obstruction/Discontinuity	>1/4" , Meters and Valves
Hwy 12/ Main St	West	Cheatham Lake Condos to Elizabeth Street	Start of Segment at Condos	Ramp	Running slope >8.3% , Cross Slope >2.0% , Break not Perpendicular
Hwy 12/ Main St	West	Cheatham Lake Condos to Elizabeth Street	Front of Gorilla Mufflers	Obstruction	Utility Pole
Hwy 12/ Main St	West	Elizabeth Street to Chestnut Street	Cheatham Co. Clerks Office Drive	Discontinuity	>1/4" between drive and sidewalk
Hwy 12/ Main St	West	Chestnut Street to Cumberland Street	On-Street Parking	Handicap Access	None
Hwy 12/ Main St	West	Cumberland Street to Mulberry Street	337' length of path		
Hwy 12/ Main St	West	212 N. Main Street	43' length of path		

Ashland City Public Buildings ADA Inventory					
Facility/Parking/Sidewalks					
Facility	Location	Observed Deficiency	ADA Standard Reference	Suggested Upgrade	Notes
City Hall & Fire Station #1 Complex	Rear Shared Parking Lot	Need 3 additional accessible spaces	208.2	Reconfigure by repainting lines & signage	Note: City Hall Complex excluded from self-evaluation due to schedule move to new, ADA compliant facility.
		No access aisle for accessible space	502.2, 502.4	Reconfigure by repainting lines	
		Not van accessible	208.2.4	Reconfigure by repainting lines	
		No entry from accessible rear entrance	208.3.1		
		No accessible route to closest entrance. Must use Sycamore St.	502.3	Create accessible route to closest entrance	
	Side Parking Lot	Not van accessible	208.2.4	Reconfigure by repainting lines	
		No signage, ground paint faded	502.6	Install required signage and repaint	
	Front Parking Lot	No accessible spaces	208.2	Reconfigure by repainting lines & signage	
	Permit Area	No signage at accessible counter (Symbol of Accessibility)	2.72	Install signage or placarding	
	City Council Chambers and Court Room				
Restroom					
Fire Department					
Fire Station #2	Parking Lot	Signage is faded, ground paint clearly marked	502.6	Install new signage at 2 spaces (includes van)	
Public Works, Parks & Police Complex	Parking Lot	Need 1 additional accessible space	208.2	Reconfigure by repainting lines & signage	
	Ramp to Sidewalk	Running slope >8.3%	406.1, 405.2	Regrade or install new Ramp	
	Sidewalk	Multiple discontinuities along 152' length & landscape obstructions	302.7.2	Evaluate for re-surfacing or replacement	
	Police Dept. Waiting Room	Service Window counter exceeds 38" height	904.3.2	Lower Counter	No public restrooms, water, phones
	Parks Dept. & Public Works	Service Window counter exceeds 38" height	904.3.2	Lower Counter	
	Restrooms	No accessibility signage for 2 restrooms	216.8	Install signage or placarding	
No safety grab bar near toilets		605.1	Install grab bar		
Door not self closing		604.8.1.2	Replace Doors		
Water Processing Plant	Parking Lot	No signage, ground paint faded	2.72	Install required signage and repaint	No public access to interior
Senior Center					Compliant
Harpeth Shoals Marina	Parking Lot	No accessible spaces	208.2	Reconfigure by repainting lines & signage	Note: Marina excluded due to 'private status'
	Ramp to Boat Slips	Running slope >8.3%	406.1, 405.2	Modify existing Ramp slope	
	Restrooms	Two non-accessible portajohns			

Ashland City Public Parks-Trails ADA Inventory					
Park/Greenway/Parking/Sidewalks					
Facility	Location	Observed Deficiency	ADA Standard Reference	Suggested Upgrade	Notes
Cumberland River Bicentennial Trail	Eagle Pass Trailhead-Parking	No accessible spaces	208.2	Reconfigure by repainting lines & signage	
		Ramp Running slope >8.3%	406.1, 405.2	Regrade or install new Ramp	
	Eagle Pass Trailhead-Trail				Upgrade to ADA only if altered or new
Cumberland River Bicentennial Trail	NW Sycamore Ridge Trailhead-Parking	No accessible spaces	208.2	Reconfigure by repainting lines & signage	
		No Crosswalk on Chapmansboro Rd., No Access to trail			
Cumberland River Bicentennial Trail	Marks Creek Trailhead-Trail				Upgrade to ADA only if altered or new
Caldwell Nature Park	Caldwell Nature Park	No accessible areas			
911 Memorial Park	Parking Lot	No signage, ground paint faded	502.6	Install required signage and repaint	
		Discontinuity entering play area	302.7.2	Evaluate for re-surfacing	Bushes need trimmed from path
	Restrooms	Discontinuity at thresholds	302.7.2	Replace with new flush or beveled thresholds	
	Sidewalk connector from play to toilets	Obstruction/Overgrowth	402.1	Cut or trim bushes	
J.W. Johns Jr. Park	Parking Lot	Access Aisle only 4'	502.2	Reconfigure by repainting lines	
		Three spaces but only two signs	502.6	After reconfiguration, install required signage	
	Parking Vine St. Field	No accessible spaces			
	Pavillion w/concessions & restrooms	Ramp to restrooms Running Slope >8.3%	406.1, 405.2	Modify Ramp slope	
		Door Opening <32"	404.2.3	Consider installing separate unisex/accessible	
	Dugouts/Bleachers/Fields	No access		Need ADA design for Sports Facilities	
Playground near Mulberry St.	Discontinuities entering play area	302.7.2	Evaluate for re-surfacing		
	Restricted accessible play area due to mulch covering	A15.6	Modify access routes or resurface play area		
Riverbluff Park	Main Pavilion and Play Area	Sidewalk abruptly ends		Install guard or ramp to drive	
		Ramps slopes from Pavilion to Play Area	406.1, 405.2	Regrade or install new Ramp	
	Parking Lot	Need 1 additional accessible space	208.2	Reconfigure by repainting lines & signage	
John C. Poole Recreation Area	Parking Lot	Access Space and Aisle not compliant	502.2	Reconfigure by repainting lines	
	Tennis Courts	Not accessible		Consider ADA re-design	
	Observation Area	Tables and benches not accessible		Consider ADA re-design	
	Restrooms				

Ashland City Signalized Intersections ADA Inventory

Main St and Cumberland St

Pedestrian Corner (see Aerial)	1 Facing 2	2 Facing 1	2 Facing 3	3 Facing 2	3 Facing 4	4 Facing 3
Ramp Type	Parallel	Perpendicular	Perpendicular	Perpendicular	Perpendicular	Parallel
Turning Space Size	3'x5'	Compliant	Compliant	Compliant	Compliant	3'x5'
Turning Space Running Slope	Compliant	Compliant	Compliant	Compliant	Compliant	Compliant
Ramp Running Slope	Compliant	Compliant	Compliant	Compliant	Compliant	Compliant
Ramp Flares	Compliant	Compliant	Compliant	Compliant	Compliant	Compliant
Width of Ramp and Turning Space	Compliant	<4'	Compliant	Compliant	Compliant	<4'
Grade Breaks	Compliant	Compliant	Compliant	Compliant	Compliant	Compliant
Cross Slopes	Compliant	Ramp >2%	Compliant	Compliant	Compliant	Ramp >2%
Gutter Counter Slope	Compliant	Compliant	Compliant	Compliant	Compliant	Compliant
Space Beyond Grade Break	Compliant	Compliant	Compliant	Compliant	Compliant	Compliant
Detectable Warning	Truncated domes too small, surface damaged	Truncated domes too small, surface damaged	Truncated domes too small, surface damaged, debris on surface	Truncated domes too small	Truncated domes too small	Truncated domes too small, surface damaged
Crosswalk Lines	Compliant	Compliant	Compliant	Compliant	Compliant	Compliant
Pushbutton at Each End of Crosswalk	Compliant	Compliant	Compliant	Compliant	No pushbutton installed	No pushbutton installed
Adjacent to All Weather Surface	Compliant	Compliant	Compliant	Compliant	n/a	n/a
Location and Distance	Compliant	>4' from crosswalk	>4' from crosswalk	>4' from crosswalk	n/a	n/a
Wheelchair Accessible Route	Compliant	Compliant	Compliant	Compliant	n/a	n/a
Distance from Curb	Compliant	Compliant	>6' from crosswalk	Compliant	n/a	n/a
Parallel to Crosswalk	Compliant	Compliant	Compliant	Compliant	n/a	n/a
Height Approximately 4'	Compliant	Compliant	Compliant	Compliant	n/a	n/a
Distance from Clear Space	>10"	Compliant	Compliant	Compliant	n/a	n/a
Multiple pushbuttons <10' apart	n/a	Yes	Yes	n/a	n/a	n/a
Locator Tone	n/a	None	None	n/a	n/a	n/a
Tactile Arrow	n/a	None	None	n/a	n/a	n/a
Speech Walk Message	n/a	None	None	n/a	n/a	n/a
Speech Pushbutton Info Message	n/a	None	None	n/a	n/a	n/a
Audible and Vibrotactile Walk Indications	None	None	None	None	None	None
Notes	Traffic light in ramp restricts it to less than 3'		"Don't Walk" visual indicator is not present or burnt out	Signal push button does not appear to function, arrow indicator on signage points in wrong direction		

Ashland City Signalized Intersections ADA Inventory

Main St and HWY 49/Frey St.

Pedestrian Corner (see Aerial)	1A Facing 2	2 Facing 1A	2 Facing 3	3 Facing 2	3 Facing 4	4 Facing 3	1A Facing 1B	1B Facing 1A
Ramp Type	Perpendicular	Perpendicular	Perpendicular	Perpendicular	Perpendicular	Perpendicular	Parallel	Parallel
Turning Space Size	3'x5'	3'x5'	Compliant	Compliant	Compliant	Compliant	Compliant	Compliant
Turning Space Running Slope	Compliant	3.2%	Compliant	Compliant	2.3%	3.5%	Compliant	Compliant
Ramp Running Slope	Compliant	Compliant	Compliant	Compliant	Compliant	8.7%	Compliant	Compliant
Ramp Flares	Compliant	13.3%	12.1%	10.4%	10.4%	12.1%	10.5%	10.5%
Width of Ramp and Turning Space	<4'	<4'	<4'	<4'	Compliant	Compliant	<4'	<4'
Grade Breaks	Compliant	Compliant	Compliant	Compliant	Compliant	Compliant	Compliant	Compliant
Cross Slopes	Ramp >2%	Ramp >2%	Ramp >2%	Compliant	Compliant	Compliant	Compliant	Compliant
Gutter Counter Slope	Compliant	Compliant	Compliant	Compliant	Compliant	Compliant	Compliant	Compliant
Space Beyond Grade Break	Compliant	Compliant	Compliant	Compliant	Compliant	Compliant	Compliant	Compliant
Detectable Warning	Truncated domes too small	Truncated domes too small	Truncated domes too small	Truncated domes too small, surface damaged	Truncated domes too small, damaged	Truncated domes too small	Truncated domes too small	Truncated domes too small
Crosswalk Lines	Compliant	Compliant	Compliant	Compliant	Compliant	Compliant	Compliant	Compliant
Pushbutton at Each End of Crosswalk	Compliant	Compliant	Compliant	No	No	No	No pushbutton installed	No pushbutton installed
Adjacent to All Weather Surface	No, pushbutton on street side of pole	Compliant	Compliant	Compliant	Compliant	Compliant	n/a	n/a
Location and Distance	>30' from crosswalk	Compliant	>4' from crosswalk	>30' from crosswalk	>30' from crosswalk	Compliant	n/a	n/a
Wheelchair Accessible Route	No	Compliant	Compliant	Compliant	Compliant	Compliant	n/a	n/a
Distance from Curb	No, pushbutton on street side directly above curb	Compliant	Compliant	Compliant	Compliant	Compliant	n/a	n/a
Parallel to Crosswalk	No	Compliant	Compliant	Compliant	Compliant	Compliant	n/a	n/a
Height Approximately 4'	Compliant	Compliant	Compliant	Compliant	Compliant	Compliant	n/a	n/a
Distance from Clear Space	>10"	Compliant	Compliant	Compliant	Compliant	Compliant	n/a	n/a
Multiple pushbuttons <10' apart	n/a	Yes	Yes	n/a	n/a	n/a	n/a	n/a
Locator Tone	n/a	None	None	n/a	n/a	n/a	n/a	n/a
Tactile Arrow	n/a	None	None	n/a	n/a	n/a	n/a	n/a
Speech Walk Message	n/a	None	None	n/a	n/a	n/a	n/a	n/a
Speech Pushbutton Info Message	n/a	None	None	n/a	n/a	n/a	n/a	n/a
Audible and Vibrotactile Walk Indications	n/a	None	None	n/a	n/a	n/a	n/a	n/a
Notes	Pushbutton not accessible, no signage indicating pushbutton location			Signal push button located >30' from crosswalk and across Rhea Alley; does not appear to function,	Signal push button located >30' from crosswalk and across Rhea Alley; does not appear to function,			

Ashland City Signalized Intersections ADA Inventory

Main St and Stratton

Pedestrian Corner (see Aerial)	1 Facing 2	1 Facing 4	2 Facing 1	2 Facing 3	3 Facing 2	3 Facing 4	4 Facing 3	4 Facing 1
Ramp Type	None	None	Parallel	Parallel	Parallel	Parallel	Parallel	None
Turning Space Size	n/a	n/a	3'x5'	Compliant	Compliant	3'x5'	3'x5'	n/a
Turning Space Running Slope	n/a	n/a	>2.0%	Compliant	3..8%	6.3%	Compliant	n/a
Ramp Running Slope	n/a	n/a	>8.3%	Compliant	9.5%	10.5%	10.3%	n/a
Ramp Flares	n/a	n/a	n/a	n/a	n/a	n/a	n/a	n/a
Width of Ramp and Turning Space	n/a	n/a	<4'	<4'	<4'	None	<4'	n/a
Grade Breaks	n/a	n/a	n/a	n/a	n/a	n/a	n/a	n/a
Cross Slopes	n/a	n/a	n/a	n/a	n/a	n/a	n/a	n/a
Gutter Counter Slope	n/a	n/a	Compliant	Compliant	Compliant	Compliant	Compliant	n/a
Space Beyond Grade Break	n/a	n/a	Compliant	Compliant	Compliant	Compliant	Compliant	n/a
Detectable Warning	None	None	Not usable, covered with rock and stone	Compliant	Truncated domes too small	Truncated domes too small	Truncated domes too small	None
Crosswalk Lines	None	None	None	None	None	Compliant	Compliant	None
Pushbutton at Each End of Crosswalk	None	One pushbutton installed	None	None	None	Compliant	Compliant	One pushbutton installed
Adjacent to All Weather Surface	n/a	Compliant	n/a	n/a	n/a	Compliant	Compliant	Compliant
Location and Distance	n/a	Compliant	n/a	n/a	n/a	>4' from crosswalk	Compliant	Compliant
Wheelchair Accessible Route	n/a	Compliant	n/a	n/a	n/a	Compliant	Compliant	Compliant
Distance from Curb	n/a	Compliant	n/a	n/a	n/a	Compliant	Compliant	Compliant
Parallel to Crosswalk	n/a	Compliant	n/a	n/a	n/a	Compliant	Compliant	Compliant
Height Approximately 4'	n/a	Compliant	n/a	n/a	n/a	Compliant	Compliant	Compliant
Distance from Clear Space	n/a	Compliant	n/a	n/a	n/a	Compliant	Compliant	Compliant
Multiple pushbuttons <10' apart	n/a	n/a	n/a	n/a	n/a	n/a	Compliant	Compliant
Locator Tone	n/a	n/a	n/a	n/a	n/a	n/a	None	None
Tactile Arrow	n/a	n/a	n/a	n/a	n/a	n/a	None	None
Speech Walk Message	n/a	n/a	n/a	n/a	n/a	n/a	None	None
Speech Pushbutton Info Message	n/a	n/a	n/a	n/a	n/a	n/a	None	None
Audible and Vibrotactile Walk Indications	n/a	n/a	n/a	n/a	n/a	n/a	None	None
Notes	No Crosswalk, ramps, curbs or accessible signals	No Crosswalk, ramps, curbs; only push button	No Crosswalk, or accessible signals; only ramp	No Crosswalk, or accessible signals; only ramp	No Crosswalk, or accessible signals; only ramp			No Crosswalk, ramps, curbs; only push button

Appendix C:

Ashland City Grievance Procedure

RESPONSIBLE OFFICE: Department of Fire & Life Safety

AUTHORITY: The Americans with Disabilities Act of 1990, as amended. TCA 4-3-2303. Title I regulations regarding employment of 29 CFR Part 1630, Title II regulations regarding public entities of CFR Part 35. If any portion of this policy conflicts with applicable state or federal laws or regulations, that portion shall be considered void. The remainder of this policy shall not be affected thereby and shall remain in full force and effect.

PURPOSE: The purpose of this policy is to state the Town of Ashland City's EEO policy of non-discrimination based on disability.

APPLICATION: All persons seeking access to programs, services or facilities of the Town of Ashland City, and all employees of the Town of Ashland City and all persons seeking employment or conducting business with the City.

DEFINITIONS: Retaliation is defined as overt or covert acts of reprisal, interference, restraint, penalty, discrimination, intimidation, or harassment against an individual or individuals exercising rights under this policy.

POLICY: It is the policy of the City to prohibit discrimination or harassment against any qualifying individual with a disability on the basis of disability in regards to the City's hiring and employment practices, or in the admission or access to, or treatment or employment in, its programs, services or activities. The City shall comply with applicable requirements of Section 503 and 504 of the Rehabilitation Act of 1973, the Americans with Disabilities Act, the Department of Personnel Policies Rules and Regulations, as well as any other applicable law pertaining to disability non-discrimination.

PROCEDURE: The Town of Ashland City hereby adopts this ADA grievance procedure issued in said document which may be revised from time to time by the city council.

HOW TO REPORT DISABILITY DISCRIMINATION INCIDENTS

If an employee, applicant for employment, or third party believes he/she has been subjected to conduct that violates this policy, he/she must report those incidents as soon as possible after the event occurs.

Employees and applicants for employment may file a complaint with the City's Department of Fire & Life Safety, Human Resources Manager, the department head, their supervisor(s), or to:

ADA Coordinator, Office of Fire & Life Safety
101 Court Street
Ashland City, TN 37015
615-792-6400

Under no circumstances is the individual alleging disability discrimination and/or harassment required to file a complaint with the alleged harasser. If an employee or applicant believes he/she cannot file a complaint within his/her department, that person should contact the Mayor's Office at 615-792-4211 ext. 228.

Individuals who wish to file a complaint are encouraged to submit the complaint in writing and to include a description of the incident(s) as well as the dates(s), time(s), place(s) and any witnesses.

HOW TO REPORT RETALIATION INCIDENTS

If an employee, applicant for employment or third party believes he/she has been subjected to retaliation for engaging in protected conduct under this policy, he/she must report incidents as soon as possible after the event occurs.

Any employee, applicant for employment, or third party who makes complaints of disability discrimination and/or harassment or provides information related to such complaints will be protected against retaliation. If retaliation occurs, the employee, applicant for employment, or third party should report the retaliation in the same manner as he/she would report a workplace harassment complaint.

HOW COMPLAINTS ARE INVESTIGATED AND RESOLVED

The ADA Coordinator in the Office of Fire & Life Safety will conduct a thorough and neutral investigation of all reported complaints of workplace disability discrimination, harassment and/or retaliation as soon as practicable. Generally, an investigation will include an interview with the complainant to determine if the conduct at issue violates this policy. If the department determines that the conduct falls within the terms of the policy, the department will interview the alleged offender and any other witnesses who have direct knowledge of the circumstances of the allegations.

The department retains the sole discretion to determine whether a violation of this policy has occurred and to determine what level, if any, of disciplinary action is warranted.

If a complaint involves an immediate supervisor, department head, the City council will investigate the complaint on behalf of the department and report the results to the appropriate agency or authority.

HOW CONFIDENTIALITY IS TREATED

To the extent permitted by law, the City will try to maintain the confidentiality of each party involved in disability discrimination and/or harassment investigation, complaint or charge, provided it does not interfere with the department's ability to investigate the allegations or to take corrective action. However, the City cannot guarantee confidentiality. Any documents that are made or received in the course of the investigation are public record under the State's Public Act, unless otherwise exempted by state law. Unless such exemption applies, state law will prevent the City from maintaining confidentiality or investigative records.

DIRECTIVE TO SUPERVISORY PERSONNEL

Supervisory personnel who receive a complaint alleging disability discrimination or learn by any means of conduct that may violate this policy must immediately report any such event to the department's Human Resources Manager, ADA Coordinator, or to the Office of the Mayor.

CORRECTIVE ACTION FOR VIOLATION OF THIS POLICY

Any employee who engages in conduct that violates this policy or who encourages such conduct by others will be subject to corrective action. Such corrective action includes, but is not limited to, mandatory participation in counseling, training, disciplinary action, up to and including termination, and/or changes in job duties or location.

Supervisory personnel who allow disability discrimination, harassment and/or retaliation to continue or fail to take appropriate action upon learning of such conduct will be subject to corrective action. Such corrective action includes, but is not limited to, mandatory participation in counseling, training, disciplinary action, up to and including termination, and/or changes in job duties or location.

OTHER PROVISIONS

When a complaint is filed, the investigator will inform the complainant, accused and witnesses of the statement of limitation on confidentiality included in the Intake/Referral process. The investigator will also inform the complainant, accused, and witnesses of the strict prohibition of retaliation, as defined in this policy.

The investigator will communicate information concerning the allegations only to those to whom the investigator is authorized to report such matters.

The investigator will issue a letter to the accuser and the accused concerning the outcome of the investigation. A copy this letter will be forwarded to the city attorney and office of the Mayor.

All documents generated by the investigation and any subsequent disciplinary action shall be preserved and only disposed of in accordance with the appropriate State rule.

Any disciplinary action taken requires that records of such action be maintained in the disciplined employee's personnel file subject to the City's policy concerning the retention of disciplinary records.

The supervisor is responsible for maintaining the proper performance level, conduct and discipline of employees under his/or her supervision. When corrective action is necessary resulting from violation of policy, the supervisor must take the appropriate disciplinary action.